



EUROPEAN MEDICINES AGENCY  
SCIENCE MEDICINES HEALTH

4 April 2012  
EMA/492627/2010  
Information and Communications Technology

## DES 3.0 Technical Guide



## Table of contents

Table of contents .....	2
<b>1. Abstract.....</b>	<b>4</b>
<b>2. Document Purpose .....</b>	<b>4</b>
2.1. How to read this document.....	4
<b>3. Actors.....</b>	<b>5</b>
<b>4. Context.....</b>	<b>5</b>
4.1. Legislation.....	5
4.2. EU Telematics Strategy .....	6
4.3. Transparency policy.....	6
4.4. Support for regulatory activities .....	6
<b>5. Architecture framework .....</b>	<b>7</b>
5.1. Definition .....	7
5.2. Paper form compliance.....	8
5.3. Interaction with eAF Systems.....	8
5.4. Interoperability .....	9
5.4.1. Current DES interoperability with other systems and databases.....	9
5.4.2. Levels of interoperability .....	9
5.5. Life cycle management .....	10
5.6. Information tracking.....	10
5.7. Relation with world-wide standards .....	10
<b>6. The standard models .....</b>	<b>11</b>
6.1. The w3c element tree diagram.....	11
6.1.1. Elements .....	11
General notation .....	11
Default representation.....	11
6.1.2. The W3C model.....	11
6.1.3. Customized patterns of the eAF.....	12
Element backgrounds patterns .....	13
<b>7. Business rules .....</b>	<b>13</b>
Example: .....	14
7.1.2. Validation .....	14
Level 1: Element validation (data structure) .....	14
Level 2: Core values, formats and constraints (basic business rules) .....	14
Level 3: Internally managed CTLs values (complex business rules) .....	14
7.2. The RDM model.....	15
RDM V1 core business concepts model .....	16
Customised patterns for RDM serialisation .....	17
7.2.1. Controlled term lists.....	17
7.3. The Common Application Form model .....	17
7.3.1. Information architecture.....	17
7.4. The specific application form information structure: .....	18

<b>8. The reference data models .....</b>	<b>19</b>
8.1. RDM v3 serialisation .....	19
8.1.1. Common Attributes.....	20
8.1.2. Control Term Lists (CTL).....	21
8.1.3. Medicinal Product .....	28
8.1.4. ATC Class .....	32
8.1.5. Pharmaceutical product .....	33
8.1.6. Route of administration .....	36
8.1.7. Ingredient .....	37
8.1.8. Packaging .....	41
8.1.9. Container .....	43
8.1.10. Authorisation.....	46
8.1.11. Procedure Technical concept .....	48
Actor .....	50
8.1.12. Target population .....	54
8.2. Common application form.....	56
8.2.1. Application.....	56
8.2.2. Attachment.....	62
8.2.3. Reference Medicinal Product.....	64
8.2.4. Legislation .....	67
8.2.5. Application Actor .....	71
8.2.6. Orphan designation.....	75
8.2.7. Paediatric Designation.....	79
8.2.8. Substance Certificates.....	83
8.3. Scientific advice .....	86
8.3.1. Specific Application Form.....	90
<b>9. About this Document .....</b>	<b>92</b>
9.1. Definitions, Acronyms, and Abbreviations .....	92
9.2. Acronyms .....	92
9.2.1. Abbreviations .....	92

## 1. Abstract

The Data Exchange Standard (DES) document is written in the context of the electronic Application Form (eAF) project sponsored by the EMA. This initiative is part of the eCTD program.

The DES describes the framework in which eAF authoring tool, eAF validation tools and eAF receiving tools were developed to support the Application Forms submission process.

DES should help facilitate communication between heterogeneous audiences (Applicants, NCA's, NtA's, EMA, etc.) for future modifications to the supported Application Forms and to the DES itself.

DES is also a framework for the IT audience for tools design and development, as well as a reference for the business to gather rules and requirements.

## 2. Document Purpose

This document describes the Data Exchange Standard version 3.0 supporting the electronic Application Form (eAF) for all application forms used between the applicants and the EMA. The first release of the standard will support the following forms:

- "Application Form for Medicinal Product for human use" (released May 2008),
- "Application form for Medicinal Product for Veterinary Use" (released October 2008),
- "Application for Variation to a Marketing Authorisation" (released December 2009) and
- "Application for Renewal of a Marketing Authorisation" (released February 2007).
- This document also contains partial information about the DES 3.0 to provide the reader with some idea of the development of the next release of this document in line with RDM V3.

The Data Exchange Standard defines the way to structure an Application Form. Using a standard model specification it describes the concepts that may be used to structure the information to exchange between parties.

### ***2.1. How to read this document.***

In association with this document the eaf\_dictionary.xsd file has the structure description of the concepts used in the DES, and in the annexes. This allows you to construct a data extraction/generation script to populate the relevant information to and from your systems.

Sections 1 to 5 present the big picture of the DES 3.0, the system architecture, how it interacts with eAF as well as a brief overview of the models used to specify it.

Sections 6 and 7 are a detailed description of concepts and the models that are used to specify the different components and entities of the system.

Finally, section 8 is a detailed presentation of the mapping between the utilised RDM entities and the xml entities used in the DES.

Use this document as-is, or with the annexes when you have to analyse a supported form (see Document Purpose).

The annexes are form specific and describe:

- The way that the model elements are mapped to the application form fields.
- The way that this document's technical concepts are involved.
- The business rules that apply to that specific form.

### 3. Actors

The following table lists the potential audience interested in the DES.

Industry – Pharmaceutical Companies
EMA / NCAs – Central Information Group (CIG)
EMA / NCAs – Product Review Team
EMA / NCAs – Scientific / Business Stakeholders
EMA / NCAs – Data Administrator
EC – DG ENTR
EMA – Project Management (PM)
EMA – IT

### 4. Context

Information provided as part of the various application forms is submitted in PDF or MS Word format. The absence of structured data in these files reduces the chances of automation regarding the validation and review, and raises issues in terms of interoperability with other systems (i.e. need to manually copy data from application forms to other systems).

The main basis of the eAF systems is to capture, submit, validate, review and store such information in structured format, for the entire submission chain. To do this the application form needs to be structured the same way for information producers (i.e. applicants) and consumers (i.e. regulators). This common structure is assured by defining a unique Data Exchange Standard (a global framework) for all application forms, assuring the features of the architecture framework described below.

#### 4.1. Legislation

The legislative bases for implementing the electronic Application Form project lies mainly in the following Directives and Regulations:

- Directive 2001/82/EC of the European Parliament and of the Council of 06/11/2001 on the Community code relating to veterinary medicinal products.
- Directive 2001/83/EC of the European Parliament and of the Council of 06/11/2001 on the Community code relating to medicinal products for human use.
- Regulation (EC) No 141/2000 of the European Parliament and of the Council of 16/12/1999 on orphan medicinal products.
- Regulation (EC) No 726/2004 of the European Parliament and of the Council of 31/03/2004 laying down Community procedures for the authorisation and supervision of medicinal products for human and veterinary use and establishing a European Medicines Agency.
- Regulation (EC) No 847/2000 of 27/04/2000 laying down the provisions for implementation of the criteria for designation of a medicinal product as an orphan medicinal product.

- Regulation (EC) No 1084/2003 of 03/06/2003 concerning the examination of variations to the terms of a marketing authorisation for medicinal products for human use and veterinary medicinal products granted by a competent authority of a Member State.
- Regulation (EC) No 1085/2003 of 03/06/2003 concerning the examination of variations to the terms of a marketing authorisation for medicinal products for human use and veterinary medicinal products falling within the scope of Council Regulation (EEC) No 2309/93.
- Regulation (EC) No 1901/2006 of the European Parliament and of the Council of 12/12/2006 on medicinal products for paediatric use and amending Regulation (EEC) No 1768/92, Directive 2001/20/EC, Directive 2001/83/EC and Regulation (EC) No 726/2004.
- Regulation (EC) No 1902/2006 of the European Parliament and of the Council of 20/12/2006 amending Regulation 1901/2006 on medicinal products for paediatric use.
- Regulation (EC) No 2309/93 of 22/07/1993 laying down Community procedures for the authorization and supervision of medicinal products for human and veterinary use and establishing a European Agency for the Evaluation of Medicinal Products.
- Regulation (EEC) No 2377/90 of 26/06/1990 laying down a Community procedure for the establishment of maximum residue limits for veterinary medicinal products in foodstuffs of animal origin.

#### **4.2. EU Telematics Strategy**

The European Union Telematics Strategy for pharmaceuticals is agreed between Member States, the EMA, and the European Commission. In order to implement European pharmaceutical policy and legislation, the various initiatives aim to increase efficiency, enhance transparency, support and facilitate the operation of procedures established by legislation.

The “Telematics Master Plan” document details the objectives and requirements for information technology (IT) tools to implement European pharmaceutical policy and legislation.

The objective of the electronic Application Form project is to better support the review process of the administrative data of medicinal product submitted, and to increase the coherence between those data so as to assure the interoperability of information within the European Regulatory Medicine Network, with the Pharmaceutical Industry and ultimately the Public.

#### **4.3. Transparency policy**

One of the principal drivers underlying the EU Telematics Strategy is a requirement for greater transparency. The proposed Electronic Application Form system is one of the tools to be employed in achieving this objective by collecting together and making available authoritative data to stakeholders.

#### **4.4. Support for regulatory activities**

The EU Telematics Strategy also foresees practical support for the operation of procedures through electronic networking, coordination and management. The proposed Electronic Application Form system will support the regulatory activities by providing a controlled and secured environment for the review process of administrative data.

## 5. Architecture framework

### 5.1. Definition

This DES 3.0 encompasses the necessary objects to build the eAF model. The DES 3.0 framework is built upon the Reference Data Model (RDM) and the Common Application form Model.

DES 3.0 documents describe:

- The data and architecture models used as a base for the framework. Reference models are described in this document and in the annexes).
- The constraints and rules for both data and architecture information. They are described in the reference models and implemented in the XSD and validation libraries.
- The commonly approved way of managing data and architecture information. See section 5.5. Life cycle management
- The various deliverables composing the Framework (libraries, configuration files,)
  - Data libraries: Contains the data information used for authoring and validation (EUTCT lists)
  - Validation libraries: Contains all the business rules used to validate the structure, some values and formats the supported eAF. The following diagram describes the different elements of the DES 3.0.

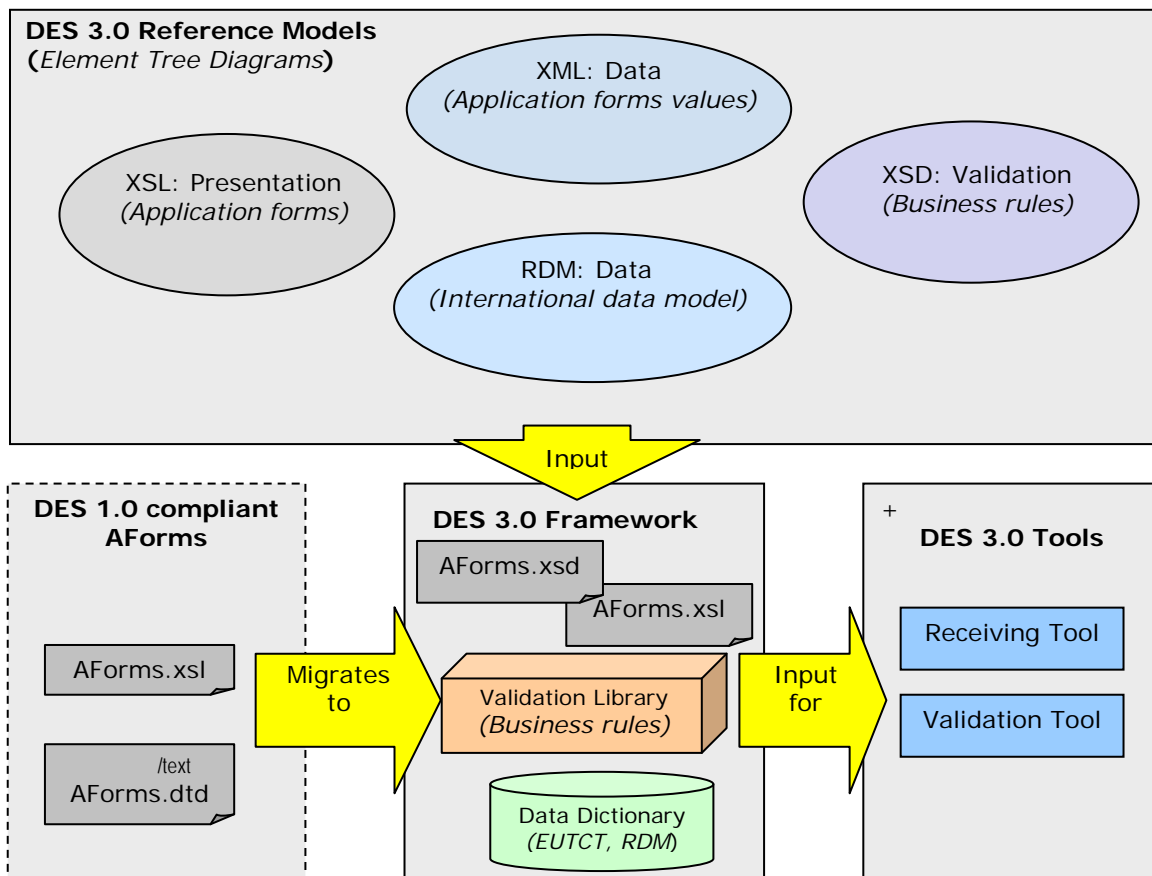

## 5.2. Paper form compliance

The first release of this document supports a series of application forms:

Form Name	Version
Marketing Authorisation (Human)	May 2008
Marketing Authorisation (Veterinary)	October 2008
Variation (Human and Veterinary)	December 2009
Renewal (Human and Veterinary)	February 2007

To ensure the compliance of the form standard model with its paper counterpart, it is more efficient to design a standard model per application form. However, as the electronic application forms will be handled by the same set of tools, it is important to base the standard models on the same framework. This framework determines the way to approach common topics, like *the inclusion of controlled terms (cf. next section)*, *the alignment to RDM*, or technical concerns like *the storage of dates, Boolean values...* The way to support identification, tracking and life cycle management should be addressed at the framework level as well.

Compliance is guaranteed if standard models are accompanied with style-sheet that allows the rendition of the application form similar to the paper form. At the level of the Data Exchange Standard, the style-sheet is designed to run within a standard browser, Microsoft Internet Explorer (IE) and Mozilla Firefox (FF) for example.

## 5.3. Interaction with eAF Systems

The eAF systems, i.e. authoring tools, validation tool and EMA receiving tool, has to be able to use (import and export) information compliant to the Data Exchange Standard (DES).

The effective storage of the information and the structure of the information within systems (i.e. to run their processes) can be different from the DES. This is a matter of system design. As a minimum the boundaries of each system must be compliant to the DES, when exchanging information between stakeholders (applicants and regulators).

The defined standards that can be used (produced, and consumed) by the eAF systems: (see section 4.1. Legislation)

The DES plays a role at all levels of the exchange and management of the information as displayed in the following diagram:



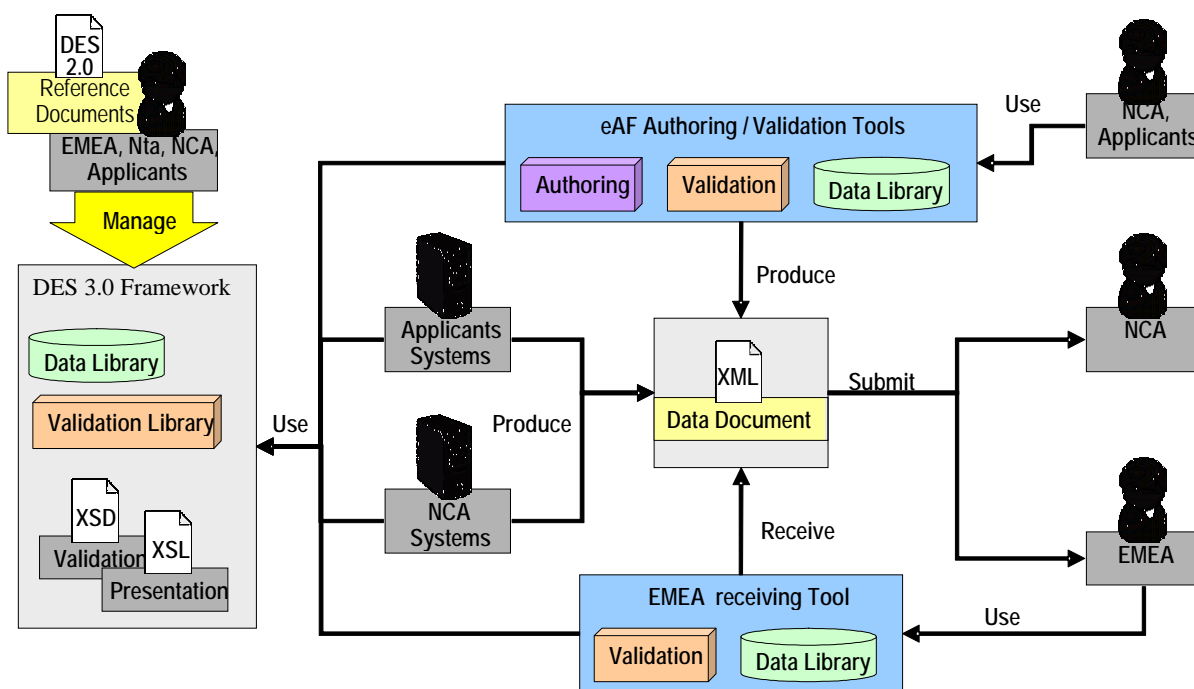

## 5.4. Interoperability

### 5.4.1. Current DES interoperability with other systems and databases

Interoperability with other systems and databases is guaranteed by the validation module composed of an XML schema and a set of business rules.

To assure the interoperability of information within the EMRN, it is essential to base the standards on RDM 3.0 and EUTCT.

- RDM provides a reference structure of the standard models so that it can be used the same way within the EMRN (semantic interoperability). See Section 8, on how the eAF concepts are mapped to the Core Concepts of RDM.
- EUTCT provides a set of controlled terminologies to be used within the forms, limit the use of free texts, and then increase the quality of data within the EMRN.

**Note:** There have been concerns about the possibility for a given applicant to retrieve non-public terms that have been entered by that applicant. Such an approach would require authentication of the applicant, which is not foreseen (and necessary) at this time. Also the cases when such circumstances would appear are considered to be rare, as terms would quickly become public for patent reasons.

### 5.4.2. Levels of interoperability

- Level 3: High interoperability is required for the concepts describing the medicinal product (RDM core concepts) and the major processes linked to it (Pharmacovigilance, Clinical-trials, GMP,) Level 1 information is also recognised by systems other than the eAF.
- Level 2: Medium interoperability is required for the concepts describing the concepts used in most application forms (declaration, legislation, references) Level 2 information is only recognised by eAF systems.
- Level 1: No interoperability is required for the information used only in a specific application form.

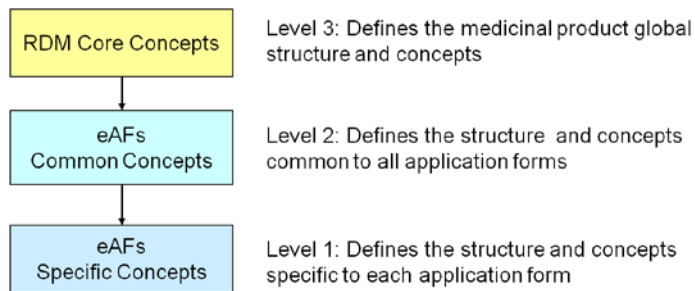

## 5.5. Life cycle management

The points which follow should be addressed to manage the delivery of the DES3.0 constituents. Lifecycle would be different for the Reference documents than for the technical deliverables (Libraries and tools).

The following aspects of each lifecycle will be addressed: version control, decision process, activities, and timelines.

## 5.6. Information tracking

The approach of the eAF DES is to rely on a single system to receive different application forms. Features must be provided to easily identify application forms and track them over time.

This information should be provided as part of the framework, within an envelope (i.e. metadata for the electronic application form). The envelope should contain:

- The type of application form.
- Identification of the application form to manage amendments (version number, or release date).
- Identification of the sender and receiver(s).
- High-level identification of the medicinal product (name, form, strength, substance; possibly according to IDMP principles).
- Identification of the procedure type (CP, MRP, DCP, or NP) and application type (e.g. New, Variation IA).

Tracking information is important to provide the necessary metadata on the application form. This is to support the storage at the correct location, the easy retrieval from the receiving tool, e.g. by filtering one or several constituents of the tracking information.

## 5.7. Relation with world-wide standards

The standard used for DES is the XML (eXtensible Markup Language) which is a subset of SGML (Standard Generalised Markup Language (ISO 8879:1986 SGML)), designed so as to make the parser much easier to implement than a full SGML parser. A consequence of the ease of implementation is that XML, rather than SGML, is widely used for deriving document specifications.

Information submitted along the application form should be compliant with RDM but also with the IDMP message (identification of medicinal products).

The eAF standard models should adopt the same structure, which is deemed to also be in line with RDM.

The eAF standard models should also adopt the identification foreseen in IDMP, for medicinal products (MedID) and for pharmaceutical products (PhPIDs). These would facilitate the interoperability within the EMRN and beyond.

## 6. The standard models

### 6.1. The w3c element tree diagram

The standard model used is the one used by W3C (World Wide Web Consortium XML Specification DTD (XML spec) for its publication standard issued in 1998.

#### 6.1.1. Elements

Any piece of information that is relevant for the communication of information between the sender, and the receiver should be included in the ETD. The smallest piece of information having a semantic signification is called an "element" (e.g. "invented-name").

An element may also have sub-elements with a more specialised signification.

**Note:** An element is also referred to as a "tag" in an XML file.

#### General notation

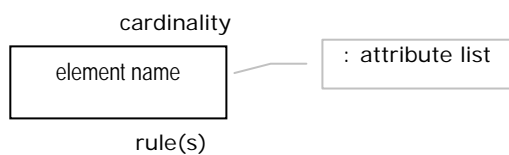

**element name** represents the name of an element. The element is represented by a square box  
**cardinality** tells what is the occurrence of the element in a specific structure. It can be optional, mandatory, unique or repeatable

**attributes list** indicate the business requirement for the following:

- attribute value data type
- attribute value format

**rules** indicate the business requirement for the following:

- element value data type
- element value format
- element dependencies with other

#### Default representation



**element name** is mandatory

**cardinality** is left blank: means "one and only one"

**attribute list** is left blank: means "no attributes"

**rules** are left blank: means the element MUST be empty (no value and no attribute(s))

#### 6.1.2. The W3C model

This model is fixed and may not be changed because it is part of an existing public model.

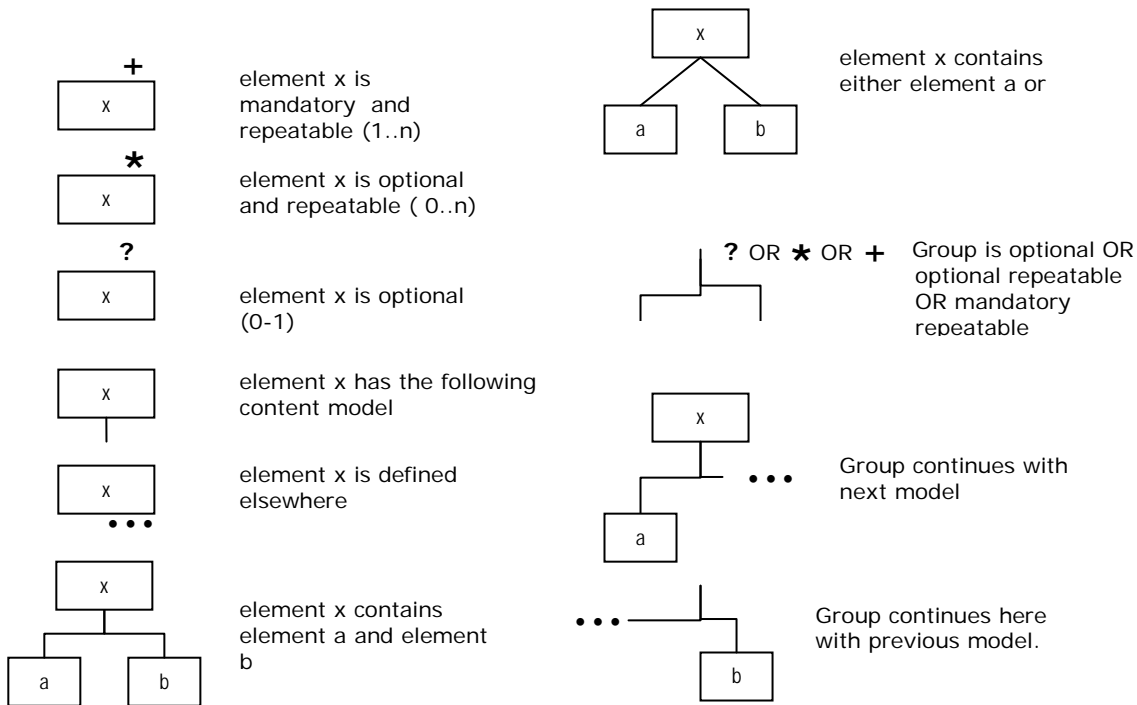

### 6.1.3. Customized patterns of the eAF

The standards have been tailored to the eAF modelling needs and the legend of the model is described below. The patterns for rules are described in the following paragraphs:

#### Customized patterns

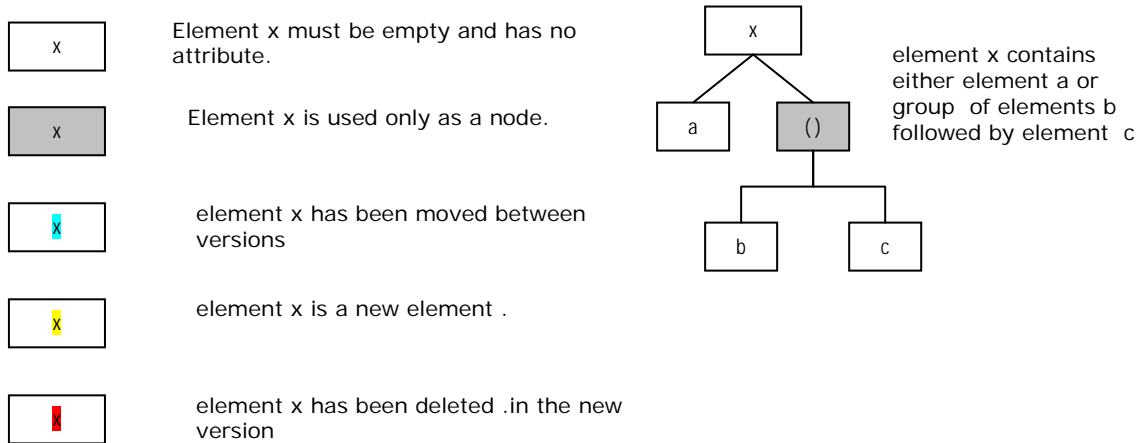

## Element backgrounds patterns

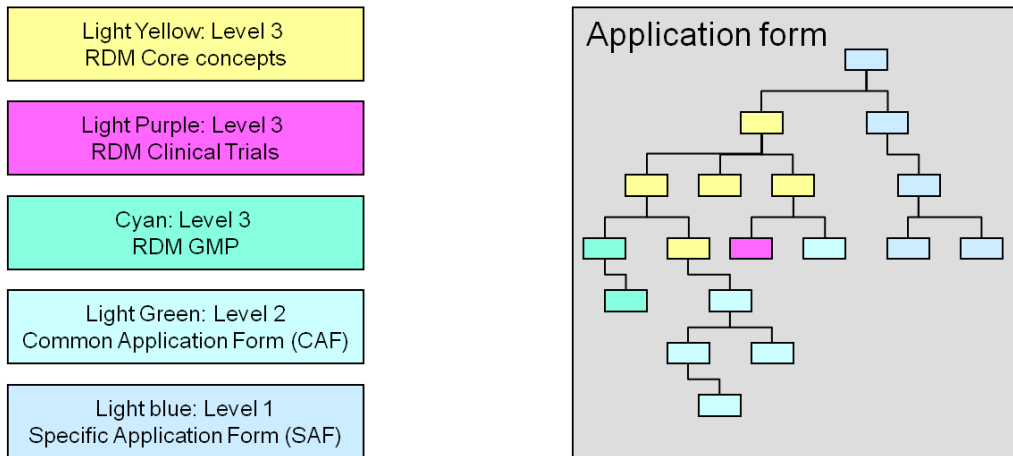

## 7. Business rules

The business rules bring specific business constraints to the model of information:

- Business rules covers only conditional constraints between elements or elements values.
- The business rules are apart from the data structure which is defined in the XML schema.

There are 2 levels of business rules as displayed in the following diagram:

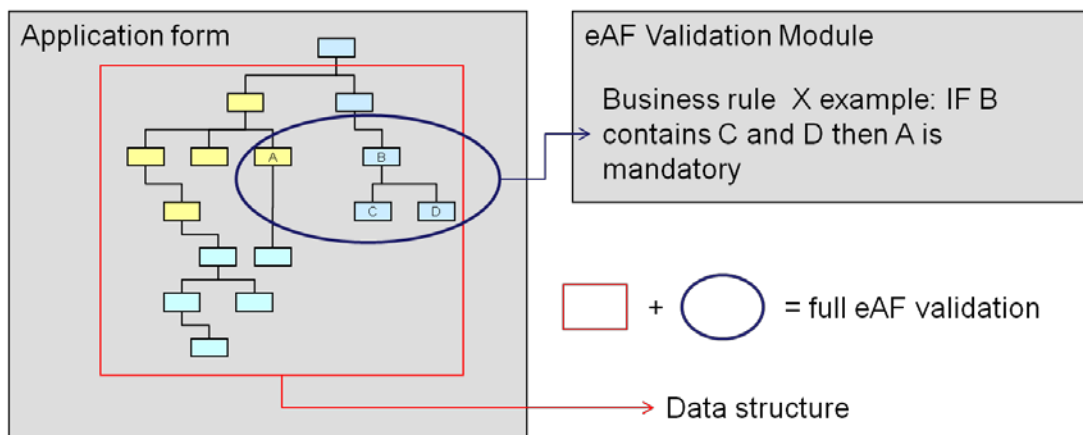

### 7.1.1. Business Rules Notation

All the rules are gathered with their corresponding Element Tree Diagram (ETD) and are defined as follows:

- **Element:** The name of the element mentioned in the (ETD).
- **Default Cardinality:** Cardinality that applies by default. It corresponds to the cardinality of the concerned element in the ETD.
- **Rule:** Description of the condition to be evaluated.

- **Effect:** if the condition is evaluated to true then the effect is applied.

**Example:**

Business Rules			
Element	Default Cardinality	Rule	Effect(s)
declaration	optional	If the product is the root element.	mandatory

**7.1.2. Validation**

The validation is based on rules derived from the interpretation of the business rules present in the application forms and defined by legislations and the business. Also validation brings boundaries for form structure and how it should be filled. The semantics of the forms are not checked at this level. Validation is built on a three tier concept.

**Level 1: Element validation (data structure)**

The validation is done only on an element or on the relationship between two elements. This includes the following validations:

- The existence (non-existence) of an element.
- The family hood of an element (parent, ancestor, child, brother).
- The logical link (XOR, OR, AND) between two or more elements.

**Level 2: Core values, formats and constraints (basic business rules)**

Core list of values and formats are defined for the electronic application form only and used only inside or across the supported forms. (E.g. Yes/No; numeric; >0 ;).

eAF only means that the validation is controlled and managed within the eAF with no business link to another model or standard (like RDM).

This includes the following validations:

- The eAF only predefined lists (Yes/No; Checked, Not Checked, not applicable ;)
- The eAF only predefined formats (numeric; Date ;...)
- The eAF only predefined constants (ZERO (0), EMPTY (""), LARGE (500), MEDIUM (50), LOW (10) ;...)
- The relation between one of the rules above and the level 1 validation.

**Level 3: Internally managed CTLs values (complex business rules)**

The validation is done based on public CTLs and existing business rules.

This includes the following validation.

- The logical link (XOR, OR, AND) between 2 CTL values
- The relation between the rule above and the level 1 validation.
- The relation between one of the rules above and the level 2 validation.

**Illustration example:**

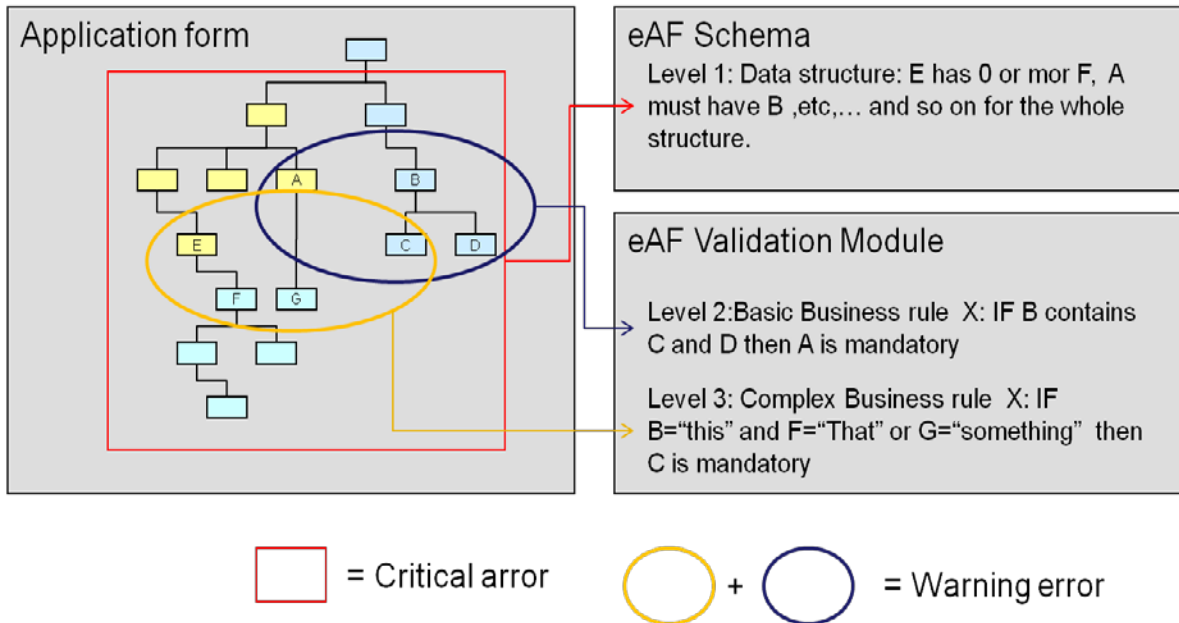

**Data type rules for Elements or Attributes values**

Rules for values only	Value in XML file
/ text(number of characters)	The value must be characters with a maximum length of "number of characters")
/ : <common attribute(s)>	The value must be of the format of the specified common attribute(s)

**7.1.3. Presentation**

The presentation is the way the data information (XML values) is displayed to the user by means of visual media. In the context of the electronic application form, the presentation should reflect the last published version of the paper application form. The media is an internet Browser or Adobe acrobat reader.

**7.2. The RDM model**

The RDM V3 model is based on the RDM V1 with extended RDM versions containing specific business information.

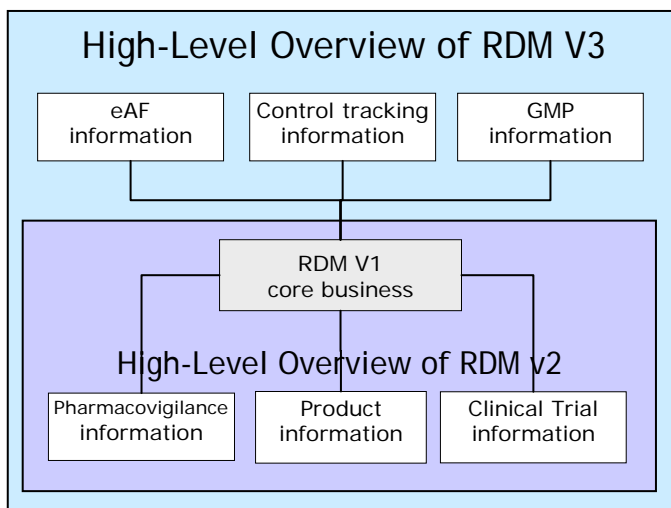

The RDM core concepts model shows the relationships between the different core business components.

### RDM V1 core business concepts model

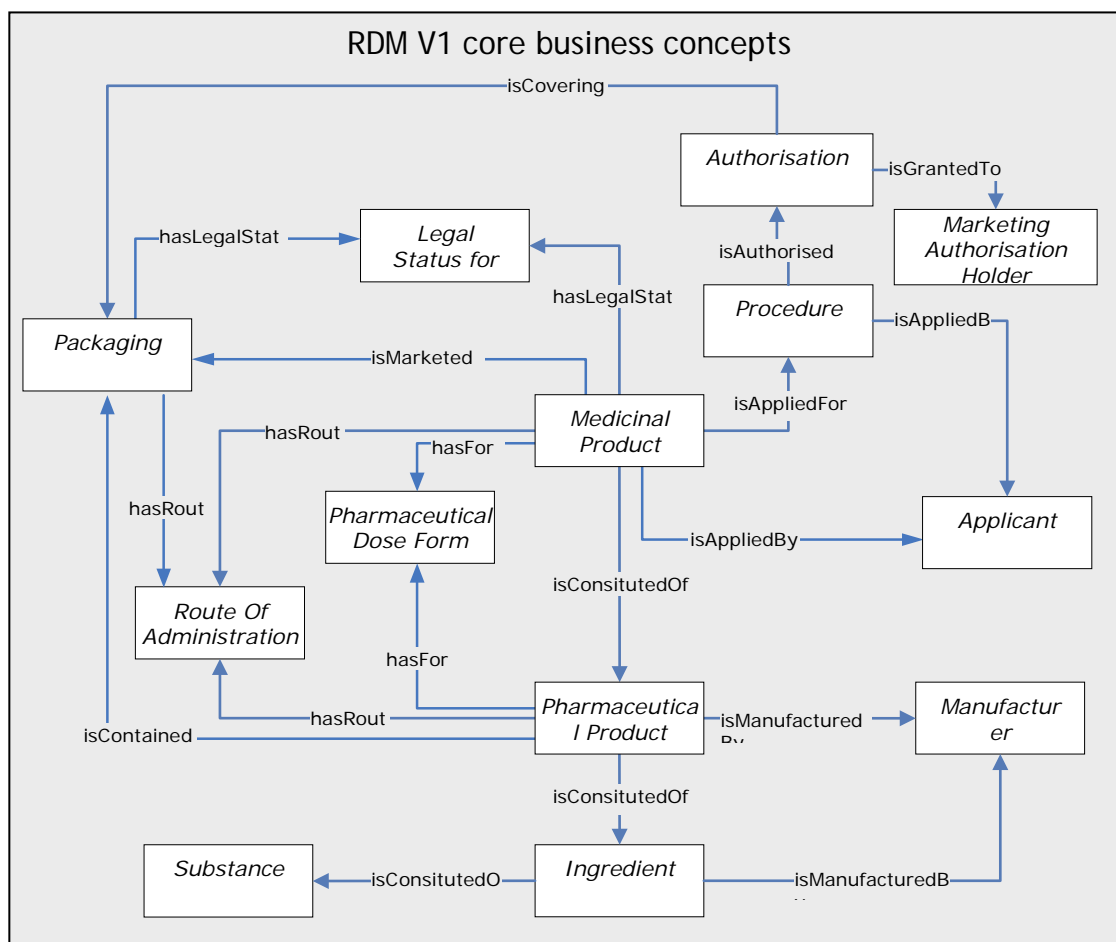

The core business concepts are composed of technical concepts describing the information type and format that can be exchanged. Technical concepts are referred to be elements in the Element Tree Diagrams (ETD`s.).



This model cannot be applied directly to the ETD`s, as it needs a serialisation process described in the sections which follow. It is interesting to keep a track of the decisions taken during the process, some new features where added in ETD notation.

## Customised patterns for RDM serialisation

The serialisation is the action to transform a relational model (database) into a hierarchical model (text) that keeps most of the constraints and structure of the relational model.

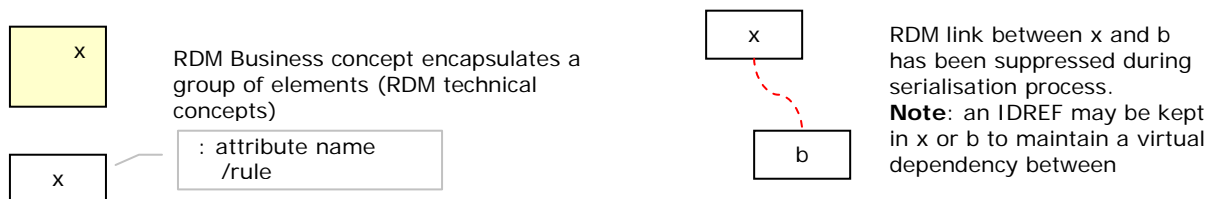

### 7.2.1. Controlled term lists

The RDM model is tightly linked to the EUTCT. Terms coming from EUTCT are always encoded with both term ID attribute, and a term value. All controlled term list (CTL) element template has been created and is described in the section below, along with the list of used EUTCT lists for eAF.

## 7.3. The Common Application Form model

The Common Application Form model is not based on any existing model. It is created based on the following rules:

- It is composed of common business concepts based on the analysis of the current supported NtA Forms.
- The re-use of common business concepts where ever possible across forms.
- Each concept is to be seen as a brick that can be used to build an NtA form structure.
- The concepts that are used only in one form will be defined and described in the NtA Form corresponding annex.

### 7.3.1. Information architecture

The information structure is based on components (single or a group of element definition) gathered in dictionaries structured by levels of interoperability which can be reused across forms.

- All forms refer to the same dictionary for level 3 (RDM core concepts) and level 2 (common AF concepts).

**Example:**

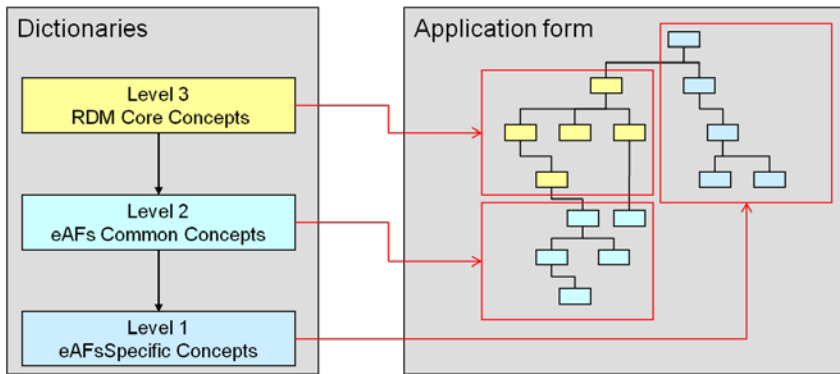

- Each form will have its own level 1 dictionary of concepts (Specific AF concepts).

**Example:**

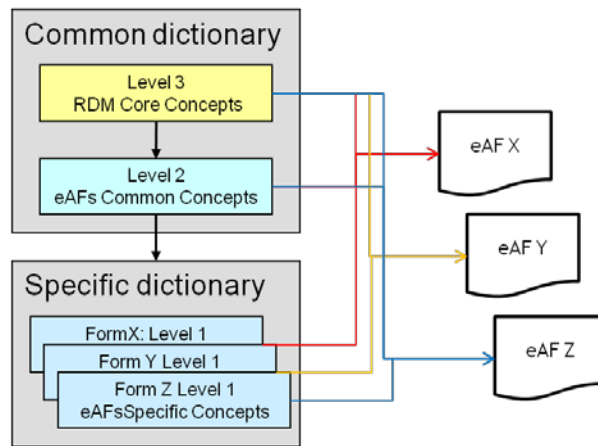

**Note:** In order to keep the level of interoperability at its highest possible rate, the model tries to reduce the level 1 dictionary elements as much as possible.

**7.4. The specific application form information structure:**

The Specific Application Form information tries to meet the following rules

- Keep the information structure as close as possible to the paper form.
- Keep the number of business concepts as low as possible.
- It separates interoperable information from specific form information, such as:
  - Questions where a specific form answer is required. (“no” versus forget to answer)
  - Information only needed for the process of the form itself (form approval status).
  - Information that could not be modelled at level 3 or level 2. (Should be moved at term).

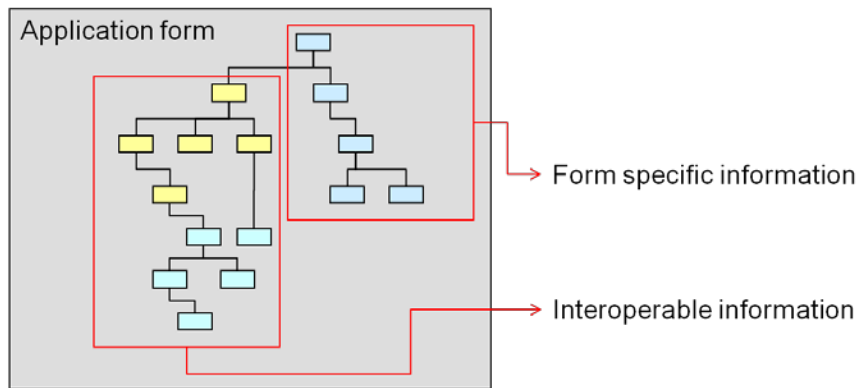

## 8. The reference data models

The reference data models contain the necessary data (information) to feed the business processes, and information about the data structure and organisation of the supported electronic application forms. They are based on the business rules captured in a graphic approach to facilitate the reading and assessment by the business.

The standard model used for XML data structure modelling is called “Element Tree Diagram” (ETD). The diagrams of this version reflect the RDM V2 core concepts described below and implemented in the validation library and XSD file.

All ETDs for the different forms are described in annexes 1 to 4 and are based on the model described in this section.

### 8.1. RDM v3 serialisation

Serialisation is the process of building a hierarchical structure (XML) from a relational structure (RDM core business concepts). It will be the base to support all forms.

The serialisation process only focuses on the RDM core business concepts. During this serialisation process a series of decisions have been taken, for example the split of cyclic relationships or the duplication of elements having relationships with several business concepts.

The following approach has been taken:

- The removed link between Medicinal product and package can be found back through the medicinal product.
- The recursive relation on the Ingredient has not been implemented. This raises an issue on the way to identify an Ingredient (See findings).
- The Authorisation information has been attached to the package, and split from the procedure, so as to assure the identification of a procedure for a medicinal product before approval.
- The Container and Pharmaceutical Product concepts have been split in the XML schema, and the link (i.e. what pharmaceutical product is in the container) has been implemented with a reference.
- As there is no information at the role level (except the role per se), the schema has been developed with the role being a repeatable field of the concept Party.

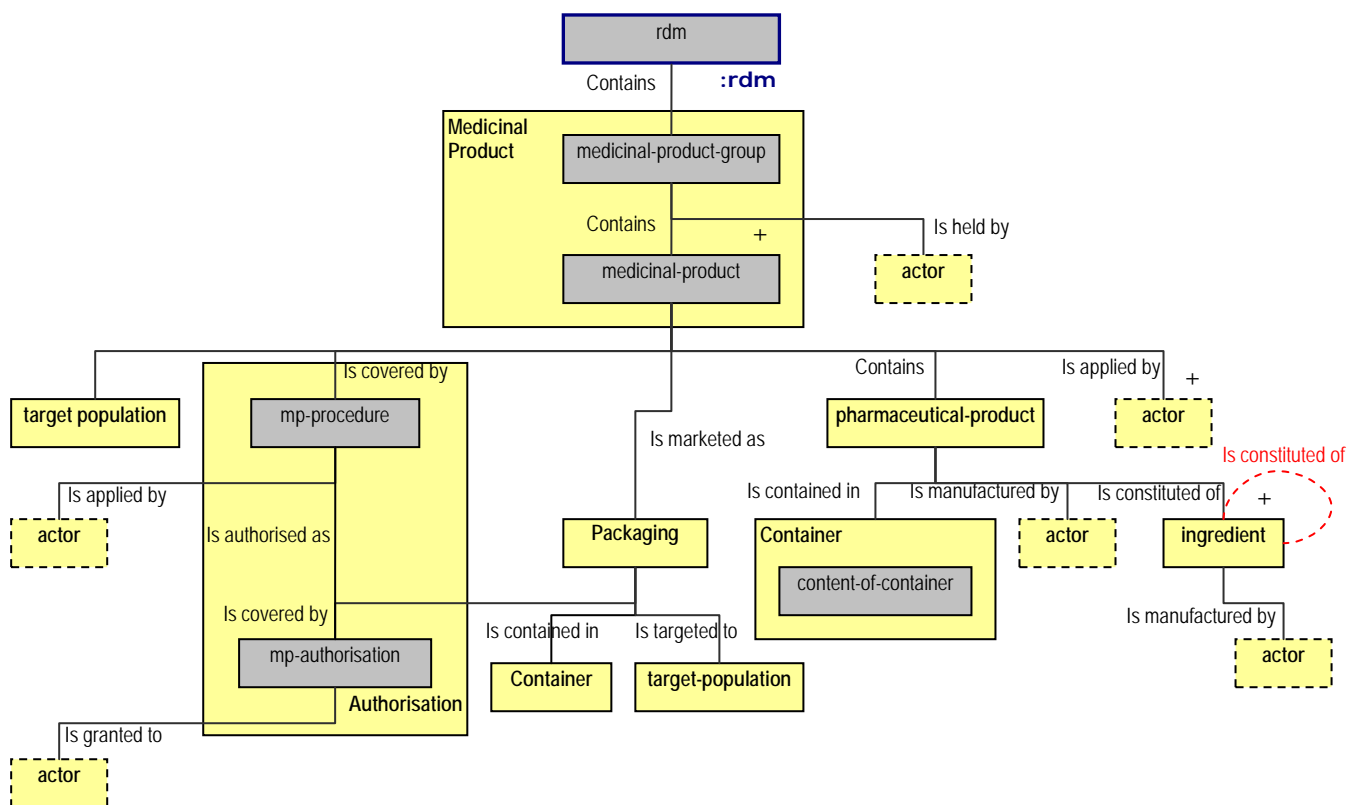

**RDM V3 future changes**

- Historical data for procedures will be added.

**8.1.1. Common Attributes**

**Unit**

Notation is “:unit”

Element	RDM Specific Format	Definition	Remarks for Structure/type/rule/format or other
Unit Version	TEXT(10)	The “Unit” controlled term revision number	
Unit Id	IDENTIFIER	The “Unit” controlled term identifier (term-id)	
Unit		The “Unit” controlled term value	

**Identifier**

Notation is “:ID”

Identifier attribute is a unique name used to identify any element in the XML form. When specified it forces the user to fill in a unique identifier for that element.

## Reference

Notation is ':reference'

The reference attribute refers to additional data in the document by using the *ID* of that element.

In other words, a reference attribute forces the user to fill in an *ID* of another element in the same document.

It is mandatory when used by an element. It stands for `:IDREFS /ID`

## Date

Notation is ':date'

Internal Date entity is the reference for the use of a date format YYYY-MM-DD for all date elements alike.

If an element declared in the validation form uses this entity then it forces any element in the XML form using this entity to have year, month and day attributes with their corresponding values.

It is mandatory when used by an element. It stands for:

```
:year / text
:month / text choice (01-12)
:day / text choice (01-31)
```

## 8.1.2. Control Term Lists (CTL)

### CTL Template

What we consider that it is mandatory for applications to store is actually 2 elements: CT ID and CT revision number. In addition to this, applications can decide to also store other elements like name, status etc.

Element	Definition	Remarks for Structure/type/rule/format or other
<element >	The element representing the name of the controlled term.	The element name may be the controlled term list friendly name.
:term-id	The term identifier (term-id).	
:ctl-version	The term revision number.	

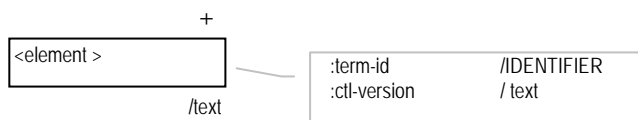

### Used CTLs

Only CTLs used by more than one technical concept are defined here. The other CTLs are defined at the Technical concepts level where they belong to.

Highlighted in yellow are the new CTLs.

The colours correspond to the model where they were created from:

- Yellow: RDM Core concepts.
- Green: Common Application form.
- Cyan: RDM GMPC.
- Grey: Not directly mapped by in the current supported electronic application forms but may be used in others.

Element <CTLName>	CTL #Range	Definition	Offline availability
Active Substance Form	see substance	The list of possible forms that an active substance may have. Example(s): (Ether; Ester; Acid; Salt)	No (Shared)
Application status (same as authorisation status)?	10	The status of an authorisation (Authorised, Pending, Refused, Withdrawn by applicant before authorisation, Withdrawn by applicant after authorisation, Suspended, revoked)	Yes (internal)
Application type	150	The type of application submitted. :MA initial"   "MA renewal"   "MA variation"   "MA pre-submission"   "Scientific advice"   "PIP	Yes (internal)
ATC	> 9000	The Anatomical Therapeutic Chemical Classification used to group medicinal products according to their indications of use for human use or veterinary use [CEN 12610:5.4.1]. Examples: A03FA (Propulsive), C01BC (Antiarrhythmic, class Ic), V04CF (Tuberculosis Diagnostics)	Yes (external)
ATC-status		The status of an atc request. (pending, assigned)	
Attachment-type		The term id that identifies the attachment or document ex: "letter of consent", "GMP certificate", "letter of authorization", "CV of qualified person", etc.	
Authorisation Status	15	The list of statuses that describe the legal situation of the marketing authorisation or any application for a marketing authorisation. Example(s): Valid; Expired; Not renewed; Withdrawn by MAH; Withdrawn, unspecified	Yes (internal)
Business category	?	The business category in which the party has is social reason. Examples: Association/Federation, EU Institutions, Hospitals or Clinics, Hotel, International Organisations, Media Institutions, National Authority in member states, National authority outside EU, Parallel Distributors, Pharmaceutical Companies, Regional Authority in EU member states, Supplier, University and education or research, unspecified.	
Contact detail type	2	Types of contacts to get in touch with the party. Example(s): Work, Home	
Container	72	The list for containers and closures, where <ul style="list-style-type: none"> <li>• a container is a physical holder, which is in direct contact with a pharmaceutical product [CEN 12610: 3.15 modified]</li> <li>• A closure is a material used to close the container.</li> </ul> Example(s): (Vial; Ampoule; Pouch; Prefilled syringe; Blister)	Yes (External)
Country	250	Geographical, political or economic area in which the identification of an ingredient, medicinal product or medicinal product package is valid [CEN 12610: 3.40]. ISO 3166 is used to store country codes (numeric IDs, alpha-2, alpha-3, including values EL and UK < <a href="http://publications.eu.int/code/pdf/370000en.htm">http://publications.eu.int/code/pdf/370000en.htm</a> >), names (short and full), and groups of countries. Example(s): Argentina; Japan; Canada	Yes (external)

Element <CTLName>	CTL #Range	Definition	Offline availability
Currency	200	The currency in which a payment is done	
Declaration condition	<20	The list of conditions assessed by the applicant in the declaration of an application form Examples for variation ("There are no other changes than those identified in this application;"; "Where applicable, national fees have been paid"; "This application has been submitted simultaneously in RMS and all CMSs "; "for work sharing only the MAs concerned belong to the same MAH"; Where applicable, all conditions as set for the variation(s) concerned are fulfilled"; "For type 1A notifications, the required documents as specified for the changes concerned have been submitted").	
difference	+ -100	Difference or changes between the reference medicinal product and the application product (change of bioavailability, change of pharmacokinetics, change or addition of a new strength / potency, change or addition of a new pharmaceutical form, change or addition of a new route of administration, change(s) in the raw material(s), change(s) in the manufacturing process(es), change in therapeutic indication(s), change in pharmaceutical form(s), change in strength (quantitative change to the active substance(s)), change in route of administration(s), other)	
Domain	3	The list of areas where a medicinal product or a term can be used. Example(s): (Human use; Veterinary use; Human and Veterinary use)	Yes (internal)
Electronic contact type	< 10	The type of electronic contact associated to the contact detail concept Examples: Phone, Fax, Email, Web, Mobile	
GMP activity		This list contains the activities that can be performed in a GMPC or a MIA site after authorisation is granted. (ex: Manufacture of active substance intermediate, Manufacture of active substance, Quality control of active substance, Sterilisation of active substance (or excipients), Manufacture of finished products intermediate, Manufacture of finished products, Quality control of finished products, Primary packaging, Secondary packaging, Batch certification, Import, Storage and distribution, Manufacture of finished products: solvent / diluents, Others)	
gmp-category		This list shows whether the certificate is GMP Certificate, Non Compliance, Distance Assessment or MRA GMP Certificate.	
ingredient-origin		The origin of the ingredient ("synthetic"; "vegetal"; "animal"; "human"; "fungus") with a classification of the tissue for veterinary application and human advanced therapies	
Ingredient Role	3	The list of roles an ingredient may have within a medicinal product composition. Example(s) (Active; Excipient; Adjuvant)	Yes (internal)

Element <CTLName>	CTL #Range	Definition	Offline availability
Legal Status for the Supply	7	<p>The list of classifications on the supply of the medicinal product/package according to Dir 2001/83/EC, Dir 2004/27/EC: article 70. It describes the way that a medicinal product/package can be supplied to the end user. Example(s)</p> <p>Class: (subject to medical prescription; not subject to medical prescription; subject to other controls)  Prescription: (veterinary product on prescription which may be renewed veterinary product on prescription which may not be renewed; veterinary product on special prescription; veterinary product on restricted prescription)  Non-prescription: (supply through pharmacies only; □ supply through non-pharmacy outlets and pharmacies supply/administration by veterinary surgeons only; supply by pharmacies and/or veterinary surgeons for animals under their care; supply through authorised distributor; general sale)  Administration: (only by a veterinary surgeon; by a veterinary surgeon or under their direct responsibility)  Promotion: (promotion to health care professionals only; □ promotion to the general public and health care professionals)</p>	Yes (internal)
Legislation Code	> 1000	The legislation code of a specific legislation that applies in the application context	
Legislation Type		Defines the type of legislation: directive"   "regulation"   "national"	
Legislation usage		<p>The usage context of the legislation or legislation article element if the code is not sufficient to determine the context of application.</p> <p>Directive 2001/83 / article 8(3) ("new active substance"; "known active substance"),  Directive 2001/83 / article 71: "renewable delivery", "not renewable delivery")  regulation1768/92/Article 8 ("supplementary protection"; "protected by patent"; "other triggering procedure")</p>	filtered by legislation / article code
Material		Constituent of an outer/immediate container. Ex: Plastic, aluminium, carton, glass...	
Medicinal Product Type	50	<p>The list of medicinal product types so as to identify the ones that may require specific provisions and/or that may need to be identified for statistical purposes.</p> <p>Examples( Cell-Therapy; Radiopharmaceutical; Immunological; Plasma-Derived)</p>	Yes (internal)
MRL Classification	6	<p>The list of the annexes of Regulation (EEC) No 2377/90 to which the MRL may belong and so as to provide the distinction between an active substance for which final/provisional maximum residue limits can/have been fixed or not and an active substance which is not included/subject to the Regulation.</p> <p>Example(s): ( Pharmacologically active substances for which maximum residue limits have been fixed.; List of substances not subject to maximum residue limits.; List of pharmacologically active substances used in veterinary medicinal products for which provisional maximum residue limits have been fixed.)</p>	Yes (internal)



Element <CTLName>	CTL #Range	Definition	Offline availability
MRL Provision	55	The list of values that indicate extra conditions as imposed on the MRL value. Example(s): (Not for use in animals from which milk is produced for human consumption; Not for use in animals from which eggs are produced for human consumption)	Yes (internal)
Party relationship type		Identifies the type of relationship the party has with its parent. (role and/or party) Examples: Site, Employee, Sub Organisation, Subsidiary	
Party type		The list of values that describe the legal standing of a party. Examples: Organisation, Person	
Payment status	5	The status of the payment transaction (not-paid, in-process, paid, refused)	
Pharmaceutical Dose Form (Dosage Form?)	350	The list of forms in which a pharmaceutical product may be presented in a medicinal product. [CEN 12610:5.4.8] Note: The pharmaceutical form has to be distinguished from the dosage form in which a medicinal product is intended to be administered to the patient, even if pharmaceutical form and dosage form are often the same Example(s): (Tablet; Syrup; Oral Suspension; Cream)	Yes (shared)
Procedure Type	10	The list of Procedure types that describe the legally defined procedures a medicinal product can be subject to during its lifecycle. These procedures refer to different areas of business containing information regarding clinical trials, marketing applications, scientific opinion, etc. Information referring to compassionate use and parallel import may be available in the future. Example(s): Centralised procedure; Mutual Recognition Procedure; Decentralised procedure; National procedure	Yes (internal)
Quantity Operator	8	The list indicating how to relate quantity value(s) of a substance in the pharmaceutical product. Example(s): (equal to; range (Two or Four values needed); less than (One value needed); more than (One value needed); less than or equal to; more than or equal to; equivalent to; approximately equal to)	Yes (internal)
Reference-medicinal-product-usage		The usage of reference declared ex ("eu marketing authorisation"; " same community/member state application"; "not less than 6/10 years in the EEA"; "demonstrated bioequivalence"; "mutual recognition procedure"...)	
Reference-monograph-standard		Type of reference to a product monograph that is intended to provide the necessary information for the safe and effective use of a new drug and also to serve as a standard against which all promotion and advertising of the drug can be compared: ("In-house"; "Ph.Eur"; "National Pharmacopoeia",...)	
Role (=actor)	50	The list contains the possible functions that may be performed by a party (organisations/persons) related to one or more activities (manufacturing, marketing, clinical trials etc) in relation to a medicinal product. Example(s): ( Person or Organisation authorised by the Sponsor; NCA (National Competent Authority); Applicant; MAH (marketing Authorisation Holder); Manufacturer; Manufacturer of biological active substance; Manufacturer of medicinal product; Manufacturer responsible for batch release; Importer; Manufacturer and Importer; CMS (Concerned Member State); RMS (Reference Member State); Responsible person for Eudravigilance; Other)	Yes (internal)

Element <CTLName>	CTL #Range	Definition	Offline availability
Route of Administration	150	The list of the parts of the body through or into which or the way in which a medicinal product is intended to be introduced [CEN 12610:5.4.15]. Example(s): (Intramuscular use; Oral use; Transferral use; Subcutaneous use)	No (Shared)
Scientific Advice Source	2	The list of the sources for scientific advice related to clinical trial and to eAF Example(s): (CHMP (Committee for Medicinal Products for Human use); NCA (National Competent Authority))	Yes (internal)
scientific-advice-type	< 10	The type of scientific advice that can be asked by the applicant. (EMA scientific advice, EMA protocol assistance, National Competent Authorities advice, FDA written request, other opinion/decision/advice)	
scientific-advice-status	< 10	The status of the current advice (received, planned, pending)	
Shelf Life Type	5	The list of the description of the condition of the medicinal product under which the given time for the shelf life is applicable. ICH Q1A (R2), CPMP/ICH/2736/99: Definition of shelf life (other name: expiration dating period): The time period during which a drug product is expected to remain within the approved shelf life specification, provided that it is stored under the conditions defined on the container level. See CHMP/ICH Guidelines: CPMP/QWP/122/02, rev 1 corr, CPMP/QWP/609/96/Rev 2, CPMP/ICH/2736/99 Examples (closed package; after first opening; after reconstitution/dilution; from manufacturing time; from time of reference; in unit-dose dispensing; after incorporation)	Yes (internal)
Special Precaution for Storage		The list of the storage conditions of the medicinal product for a particular package. Example(s): (Do not store above 25°C; Do not store above 30°C; Store below 25°C; Store below 30°C)	
Species	250	The list of the groups of animal species or sub species for which the marketing organisation of a medicinal product is approved as indicated in the annexes of Regulation No (EEC) 2377/90. Example(s): (Species: Cattle, Pigs, Horses, Sheep, Salmon fish; Sub-species: new born calves)	Yes (internal)
Substance	> 13000	The list of active substances, i.e. any composition of matter that has a discrete existence, irrespective of origin, which may be which may be human, animal, vegetable, or chemical.[ISO 11238]. Examples: (Clonazepam; Human recombinant insulin)	No (shared)

Element <CTLName>	CTL #Range	Definition	Offline availability
Tissue	12	<p>This Controlled Term List covers the tissue terms that are connected with centralised establishment of Maximum Residue Limits (MRL) (Community procedure) for pharmacologically active substances used in food producing animals and with following determination of withdrawal periods for foodstuff of animal origin (edible tissues) during marketing authorisations of products containing these substances.</p> <p>According to Regulation (EEC) No 2377/90, MRL is defined as: "The maximum concentration of residue resulting from the use of a veterinary medicinal product (expressed in mg/kg or µg/kg on a fresh weight basis) which may be accepted by the Union to be legally permitted or recognized as acceptable in or on a food".</p> <p>In Directive 2001/82/EC (2004//28/EC): 9. Withdrawal period is "The period necessary between the last administration of the veterinary medicinal product to animals, under normal conditions of use and in accordance with the provisions of this Directive, and the production of foodstuffs from such animals, in order to protect public health by ensuring that such foodstuffs do not contain residues in quantities in excess of the maximum residue limits for active substances laid down pursuant to Regulation (EEC) No 2377/90."</p> <p>Example(s): (All relevant tissues; Fat; Honey; Liver; Milk)</p>	Yes (internal)
Unit	> 500	The list of the units and measurements. Example(s): (mg; ml; µg/kg; day; month; year)	Yes (Shared)
Variation grouping	<10	<p>The Grouping indicates whether the applications include one or more variations, including or not the line extensions, or worksharing.</p> <p>Examples (Single Variation, Grouping of variations; grouping of variations including line extension; Worksharing)</p>	
Variation classification	<500	<p>The description of the variation that corresponds to the classification as described in the regulation 1234/2008 annex II. The classification is structures as the following:</p> <p>Guideline Section (A, B, C, D...). Guideline number. Guideline index (Examples "The codes that identifies a variation item. B.a or B.2.C.</p>	
Variation-type	< 10	<p>Gather all types of variation type in the application as defined in the regulation 1084/2003 article 2 plus additions from the variation guidelines for foreseen and unforeseen variation of type IB and type IA in.</p> <p>Examples (Type IA, Type IA IN, Type IB, Type IB unforeseen, Type IB foreseen, Type II, Type II Art.29,)</p>	
Variation domain	<10	<p>The different domains in which the changes occur.</p> <p>Examples(Indication, Paediatric indication, Safety, Safety following urgent safety restriction, quality, Annual variation for human influenza vaccines, Non-food producing target species, Other)</p>	

### 8.1.3. Medicinal Product

#### *Medicinal Product (Business Concept)*

Element	Definition	Remarks for Structure/type/rule/format or other
rdm	A Medicinal Product consists of a substance, a combination of substances or a preparation of substance(s), which may be used in or administered to human beings or animals, with a view to treat, prevent or diagnose diseases- Directive 2004/27/EC (See Articles 1b, 1c); Directive 2004/28/EC (See Article 1b)	
medicinal-product-group	The grouping of all medicinal products marketed by the same marketing authorisation holder with the same active substance(s) less than one name or several closely related names. A group can be considered as a family of products. A group is often what people refer to when they refer to a medicine.	
actor	See Actor business concept	Role="Holder"
medicinal-product	<ul style="list-style-type: none"> <li>• Any substance or combination of substances presented as having properties for treating or preventing disease in human beings; or</li> <li>• Any substance or combination of substances which may be used in or administered to human beings with a view to restoring, correcting or modifying physiological functions by exerting a pharmacological, immunological or metabolic action, or to making a medical diagnosis. [Directive: 2004/27/EC: 1.b].</li> <li>• Any substance or combination of substances presented as having properties for treating or preventing disease in animals; or</li> <li>• Any substance or combination of substances which may be used in or administered to animals with a view either to restoring, correcting or modifying physiological functions by exerting a pharmacological, immunological or metabolic action, or to making a medical diagnosis [Directive: 2004/28/EC: 1.b].</li> <li>• Any medicinal product prepared from substances called homeopathic stocks in accordance</li> </ul>	

Element	Definition	Remarks for Structure/type/rule/format or other
	<p>with a homeopathic manufacturing procedure described by the European Pharmacopoeia or, in the absence thereof, by the pharmacopoeias currently used officially in the Member States. A homeopathic medicinal product may contain a number of principles. [Directive: 2004/27/EC: 1.c].</p> <ul style="list-style-type: none"> <li>Any medicinal product, exclusively containing as active ingredients one or more herbal substances or one or more herbal preparations, or one or more such herbal substances in combination with one or more such herbal preparations [Directive: 2004/24/EC: 1.30].</li> </ul>	
authorisation	See Authorisation business concept	
packaging	See Packaging business concept	
actor	See Actor business concept	Role="Applicant"
pharmaceutical-product	See Pharmaceutical product business concept	

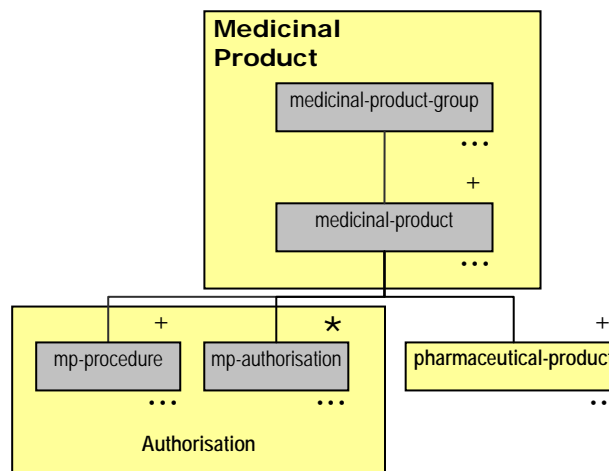

**Medicinal product group (Technical Concept)**

DES 3.0 Element	RDM Specific Format	Definition and remarks	RDM 3.0 mapping	Remarks for Structure/type/rule/format or other
medicinal-product-group	-	See Medicinal product group technical concept	Medicinal Product Group >	
is-gmo	string	Flag to indicate whether the medicinal product group belongs to genetically modified organisms (GMO) or not. If this flag is true, the medicinal product group is GMO.	Application > App GMO > mp consist of gmo	Value = "yes"   "No"
invented-name	NAME	The family name used to describe all the products in the group. E.g. Actos, Humalog, Fendrix, Optaflu.	Invented name	
domain /term-id /short name	IDENTIFIER + TERMNAME	See used CTLs	Domain CTL > term id	
medicinal-product-type /term-id /short name	IDENTIFIER + TERM NAME	See used CTLs	Medicinal Product Type CTL > term id	The Medicinal Product Type (in Medicinal Product Group) contains different types of information (usually connected to the substance) while EudraPharm only uses "Medicinal Product". In the examples, the only type used is "Medicinal Product".

## Element Tree Diagram

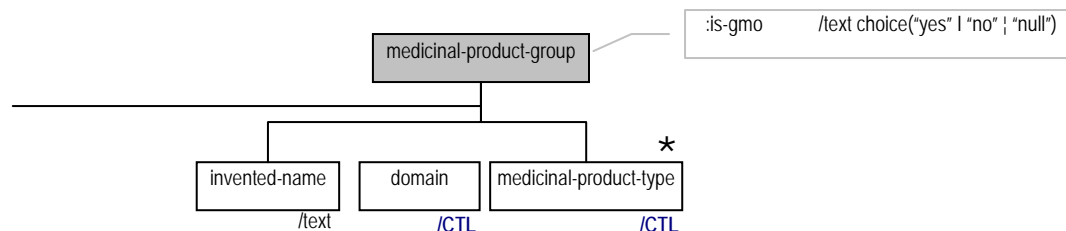

## Medicinal Product (Technical Concept)

DES 3.0 Element	Definition	RDM 3.0 Mapping	Remarks for Structure/type/rule/format or other
medicinal-product (mp)*	-	Medicinal Product >	
mp-name	Name of the medicinal product. E.g. Actos, Humalog Basal.	Medicinal product name	
mp-renewal-date	Date on which the latest renewal of the marketing authorisation was granted.	Mp procedure > Procedure use > proposed common renewal date	
eudraCT-number	This domain is introduced to define the attributes having eudract number.	Application > Contract Company CT > eudract number	
Member-state-of-source	Member state where the source is from	Reference Member State > Country CTL	
pharmaceutical-dose-form	See used CTL	Pharmaceutical Dose Form > term id	Not used?

### Element tree diagram

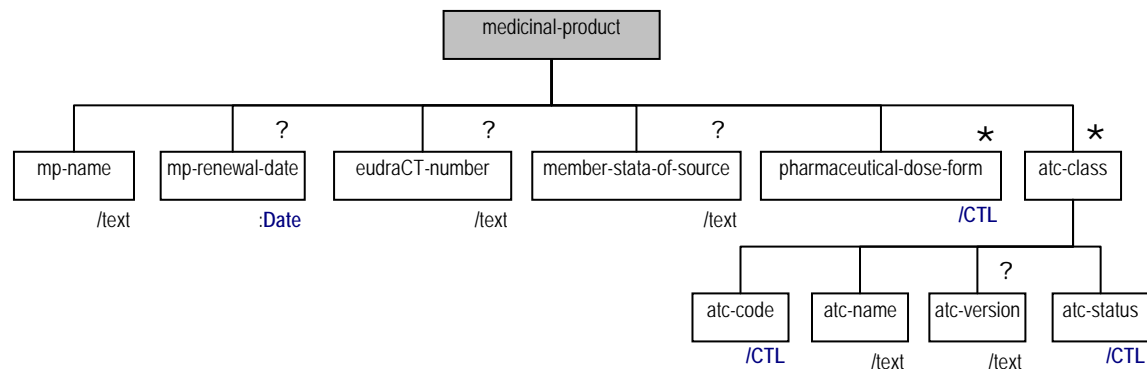

### 8.1.4. ATC Class

DES 3.0 Element	Definition	RDM 3.0 Mapping	Remarks for Structure/type/rule/format or other
atc-class	The medicinal product classification.	ATC Code CTL	
atc-code	See ATC CTL	ATC Code CTL > term id	
atc-name	The corresponding name to the classification code	Not mapped	
atc-status	See atc-status CTL	ignored	



### Element tree diagram

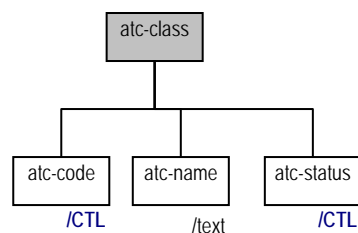

## 8.1.5. Pharmaceutical product

### Pharmaceutical product (Business concept)

DES 3.0 Element	Definition	RDM 3.0 Mapping	Remarks for Structure/type/rule/format or other
pharmaceutical-product	A Pharmaceutical Product reflects the active ingredient(s), strength(s), pharmaceutical dosage form(s) and routes of administration(s) that constitute a medicinal product - ICH M5: Data Elements and Standards for Drug Dictionaries (See Section 2.3.5)	Pharmaceutical product	

DES 3.0 Element	Definition	RDM 3.0 Mapping	Remarks for Structure/type/rule/format or other
packaging	See packaging business concept	Packaging	Packaging keeps link with pharmaceutical product only
ingredient	See ingredient business concept	Ingredient	Role="Applicant"
actor	See actor business concept	Role Party	
container	See container business concept	Outer Container Immediate Container Content of Container	The Container and Pharmaceutical Product concepts have been split in the XML Schema, and the link

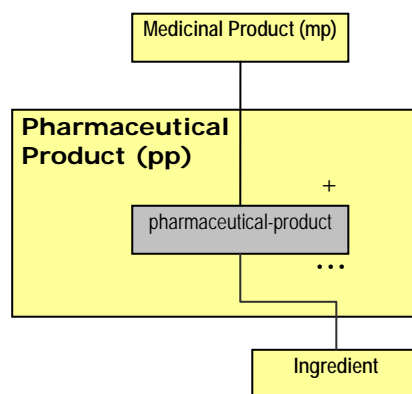

**Pharmaceutical Product (Technical concept)**

DES 3.0 Element	RDM Specific Format	Definition	RDM 3.0 Mapping	Remarks for Structure/type/rule/format or other
pharmaceutical-product (pp)*	-		Pharmaceutical Product	
pharmaceutical-dose-form	IDENTIFIER + TERM NAME	See used CTLs	Pharmaceutical Dose Form CTL > term id	

\* Abbreviation pp has to be replaced by the full name when using XML.

**Element Tree Diagram**

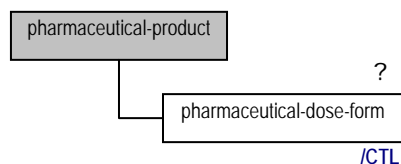

### 8.1.6. Route of administration

#### *Route of administration (Technical concept)*

DES 3.0 Element	RDM Specific Format	Definition	RDM 3.0 Mapping	Remarks for Structure/type/rule/format or other
route-of-administrations	-	-	-	-
route-of-administration	IDENTIFIER + TERM NAME	See used CTLs	Route of Administration CTL > term id	

#### *Element Tree Diagram*

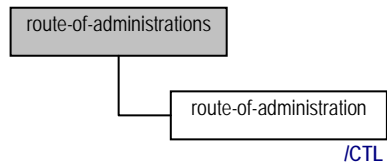

### 8.1.7. Ingredient

#### *Ingredient (Business concept)*

Element	Definition	RDM 3.0 Mapping	Remarks for Structure/type/rule/format or other
ingredient	An Ingredient is a substance, active or not, that is included as a component in a pharmaceutical product. - CEN 12610:3.16 HALOFUGINONE 0.050 g (For medicinal product Halocur – Oral solution HALOFUGINONE 0.5 mg/ml)	Ingredient	

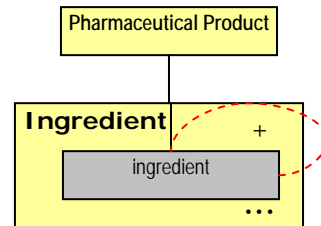

**Ingredient (Technical concept)**

Element	Definition	RDM 3.0 Mapping	Remarks for Structure/type/rule/format or other
ingredient	-	Ingredient >	
low-strength-numerator-value	Strength value for low numerator.	low strength numerator	
low-strength-denominator-value	Strength value for low denominator.	low strength denominator	
high-strength-numerator-value	Strength value for high numerator.	high strength numerator	
high-strength-denominator-value	Strength value for high denominator.	high strength denominator	
strength-denominator-unit	Unit for the denominator values	Unit CTL	
strength-numerator-unit	Unit for the numerator values	Unit CTL	
substance	See used CTLs	Substance CTL > term id	
ingredient-role	See used CTLs	Ingredient Role CTL > term id	
quantity-operator	See used CTLs	Quantity Operator CTL > term id	
overage	An overage is a fixed amount of the drug substance in the dosage form that is added in excess of the label claim.	Active-substance overage excipient overage	
substance	See used CTLs	Substance CTL > term id	
overage-quantity	Quantity of substance overage	-	
quantity-operator	See used CTLs	-	
Reference-monograph-standard	Type of reference to a product monograph that is intended to provide the necessary information for the safe and effective use of a new drug and also to serve as a standard	Pharmaceutical product > Medicinal Product > Application > App PMF Certificate >	

Element	Definition	RDM 3.0 Mapping	Remarks for Structure/type/rule/format or other
	against which all promotion and advertising of the drug can be compared: (“In-house”; “Ph.Eur”; “National Pharmacopoeia”,...)		
ingredient-origin	The origin of the ingredient (“synthetic”; “vegetal”; “animal”; “human”; “fungus”)	Pharmaceutical product > Medicinal Product > Application > manufacturing Material > Material Origin CTL	

### Element Tree Diagram

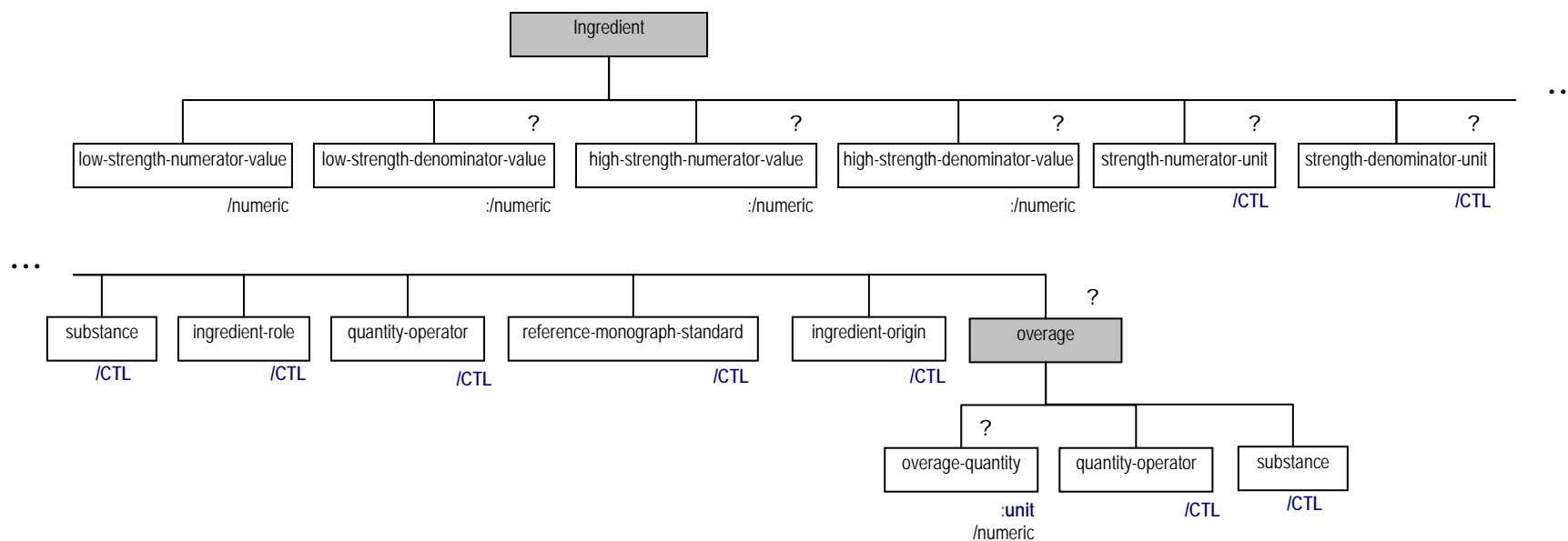

Business Rules

Element	Default BR	Rule
*_ Strength- *	-	<ul style="list-style-type: none"> <li>• No strength value can be zero or less.</li> <li>• Low strength value (numerator/denominator) must be less than high strength value (numerator/denominator).</li> <li>• No strength value can be provided without units.</li> <li>• If quantity operator is 'equal to', 'equivalent to' or 'approximately equivalent to' then elements low strength numerator value and low strength denominator value should be used to describe strength.</li> <li>• If quantity operator is 'range' then               <ul style="list-style-type: none"> <li>• Elements low strength numerator value and low strength denominator value should be used to describe the low strength.</li> <li>• Elements high strength numerator value and high strength denominator value should be used to describe the high strength.</li> </ul> </li> <li>• Units provided must be same for low and high strengths</li> <li>• If quantity operator is 'less than' or 'less than or equal to' then elements high strength numerator value and high strength denominator value should be used with their strengths.</li> <li>• If quantity operator is 'more than or equal to' then elements low strength numerator value and low strength denominator value should be used with their strengths.</li> </ul>



## 8.1.8. Packaging

### *Packaging (Business Concept)*

Element	Definition	RDM 3.0 Mapping	Remarks for Structure/type/rule/format or other
packages	-	-	
package	Packaging covers the delivery units of a medicinal product, in an outer container, including the container information in those packages. [CEN 12610: 3.26] Example(s): (Actos – 28, blister (alu/alu) ; 1 box of Karvea containing 2 x 14-tablet blisters; 1 box with 60 vials of Fuzeon powder + 60 vials solvent + 60 3ml syringes + 60 1ml syringes + 180 alcohol swabs)	package	
container	The container information in a particular package	Outer container	
Attachment	See attachment business concept	ignored	

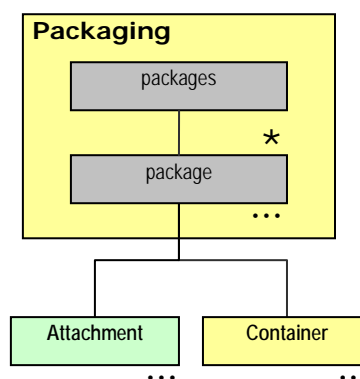

**Package (Technical Concept)**

DES 3.0 Element	Definition	RDM 3.0 Mapping	Remarks for Structure/type/rule/format or other
Package	-	Package >	
package-name	Contains the name of the package. E.g. Actos, Actraphane 10 Penfill.	package description	
package-size	Size of the package including the number of tablets or size of package having vials. E.g. 28, blister (alu/alu)	package size	

**Element Tree Diagram**

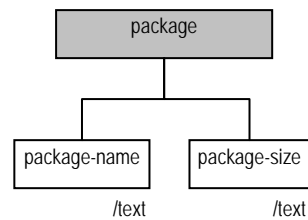

## 8.1.9. Container

### *Container (Business concept)*

Element	Definition	RDM 3.0	Remarks for Structure/type/rule/format or other
outer-container	Physical delivery unit of the medicinal product or any container that is not in direct contact with the pharmaceutical product. It is also the Inner/Immediate container which is defined as: Container which is in direct contact with the pharmaceutical product [ENV 12610:1997 – 3.14]	Outer Container Immediate container	
container	Structure element		
shelf-life	This entity contains the information about time of usage of the outer container. Example: Medicinal product 'Halocur – Oral solution HALOFUGINONE 0.5 mg/ml' has the shelf life information as 'Shelf-life of the veterinary medicinal product as packaged for sale: 3 years. Shelf-life after first opening the container: 6 months'. This entity contains two shelf lives as 3 years while the package remains closed and 6 months after first opening	Shelf Life	
administration-device	This entity contains the administration devices information in the package:	Administration device	

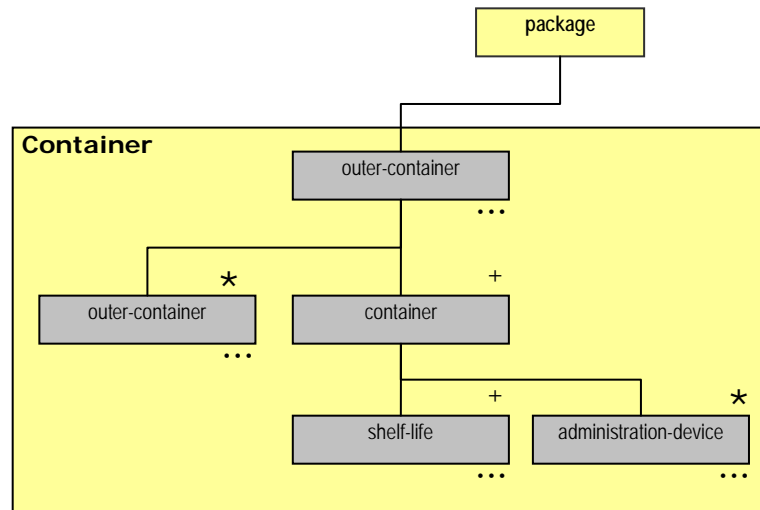

**Container (Technical Concept)**

DES 3.0 Element	Definition	RDM 3.0 Mapping	Remarks for Structure/type/rule/form at or other
outer-container	-	Outer Container	
Is-also-immediate-container			Not used
outer-container	-		
description	Textual description of the package	outer container desc immediate container desc	Initial-application-form
container	See list of CTL	Not mapped	
container-material	See materiel CTL	Material CTL > term id	

DES 3.0 Element	Definition	RDM 3.0 Mapping	Remarks for Structure/type/rule/format or other
closure	A closure is a material used to close the container. (ex: Aluminium cap) See container CTL	Closure CTL > term id	
closure-material	See materiel CTL	Material CTM > term id	
shelf-life	-	Shelf life	
shelf-life-duration	The period and unit of time that determine the limit of use defined by the shelf-life type.	shelf life duration	
shelf-life-type	See list of CTL	Shelf Life Type CTL > term id	
special-precaution-for-storage	See list of CTL	Precaution for storage > Special Precaution for Storage CTL > term id	
administration-device		-	
administration-device	See list of CTL	Administration Device CTL > term id	
material	See list of material CTL	Material CTL > term id	

## Element Tree Diagram

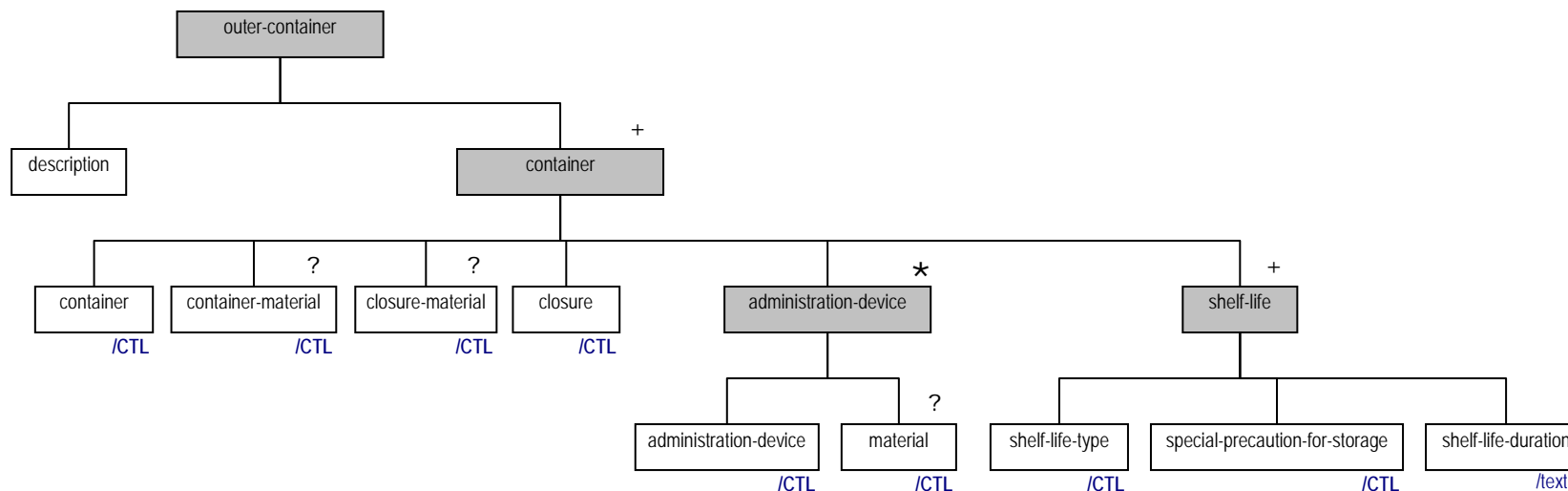

### 8.1.10. Authorisation

#### Authorisation (Business Concept)

3.0 Element	Definition	RDM 3.0 Mapping	Remarks for Structure/type/rule/format or other
mp-procedure	The Authorisation procedure followed for the granting of the marketing authorisation. The procedure number corresponds to a common identification. Examples: EMEA/H/C/000285 (For a centralised	MP Procedure	The mp-procedure may contain itself for historical data purposes in case of an MRP.

3.0 Element	Definition	RDM 3.0 Mapping	Remarks for Structure/type/rule/format or other
	procedure)		
mp-authorisation	<p>Authorisation covers the information on procedure and authorisation related to the marketing of medicinal products. (Regulation (EEC) N° 2309/93 (see article 3))</p> <p>The authorisation information of the medicinal products.</p> <p>Example(s): For a centralized Human Medicinal Product            Authorisation number: EU/1/00/150/001            Date: 13 October 2000            Status: Authorised by Marketing Authorisation Holder</p>	MP Authorisation	The Authorisation information has been attached to the Package, and split from the Procedure, so as to assure the identification of a procedure for a medicinal product before approval.
actor	See Actor business concept	Role Party	Role = "marketing authorisation holder"
Application	See Application business concept	Application	Role="applicant", "rapporteur", "co-rapporteur"

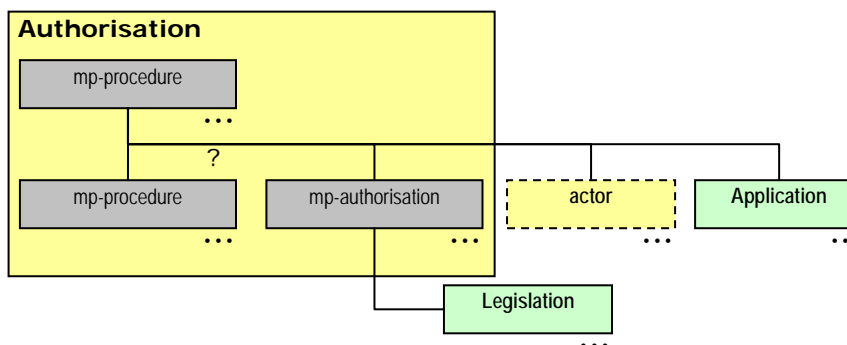

### 8.1.11. Procedure Technical concept

Element	Definition	RDM 3.0 Mapping	Remarks for Structure/type/rule/format or other
mp-procedure		MP Procedure >	
procedure-number	The procedure number corresponds to a common identification of the procedure. E.g. EMEA/H/C/000071 is a centralised procedure number.	procedure number	
procedure-start-date	Date on which the procedure was started.	procedure start date	
proposed-date	The common agreed proposed date. This date depends on the type of procedure (ex: proposed date for type "renewal" is the proposed renewal date"	Procedure Use > proposed common renewal date	origin: AF Renewal
expiry-date	Date of expiry of current authorisation in the reference member state or community:	MP Procedure > rms current auth expiry date	
acceptance-date	The date when the procedure was accepted to be launched	chmp acceptance date	
country	See country CTLs The concerned member state	Role > country	
procedure-type	See procedure-type CTLs	Procedure Type CTL > term id	
wave-number	The sequence number of the procedure for the same medicinal product	Procedure Use > wave id	Range for 0 (first authorization) to n origin: AF MAA
please-specify-information	Renewals info		
renewal-date	Renewal common date		



### Element Tree Diagram

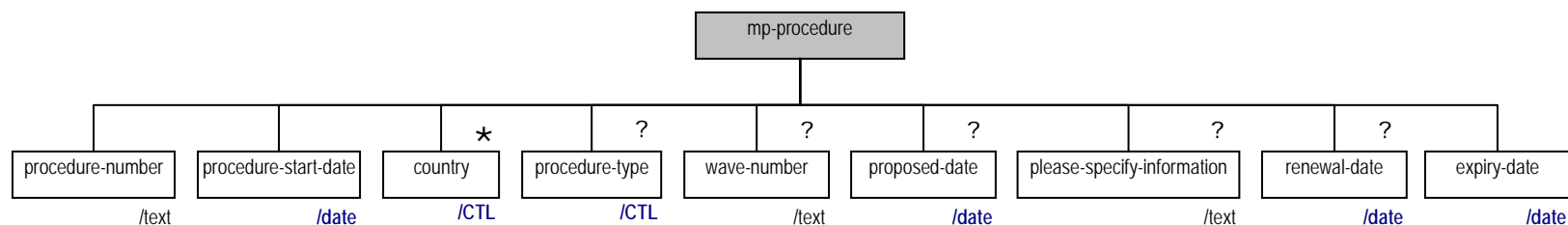

### Authorisation (Technical Concept)

Used in: mp-procedure; medicinal-product; reference-medicinal-product/medicinal-product-group/medicinal-product

Element	Definition	RDM 3.0 Mapping	Remarks for Structure/type/rule/format or other
mp-authorisation		MP Authorisation >	
:is marketed	Tell is the product already has a marketing authorisation		
authorisation-number	Authorisation number granted by the relevant authority (EMEA, NCAs ). E.g. EU/1/00/150/001.	authorisation number	
authorisation-holder		Role > Organisation > name	
authorisation-date	Date on which the marketing authorisation was granted, either in a centralised or in a national procedure	Authorisation Date	
country	See used CTL The country for which the authorisation is given. The country may be the reference member state or the concerned member state depending on the application.	Country CTL	

Element	Definition	RDM 3.0 Mapping	Remarks for Structure/type/rule/format or other
authorisation-status	See used CTL	Authorisation Status	
expiry-date	Date of expiration of the current authorisation in concerned member state	MP Procedure > cms current auth expiry date	

### Element Tree Diagram

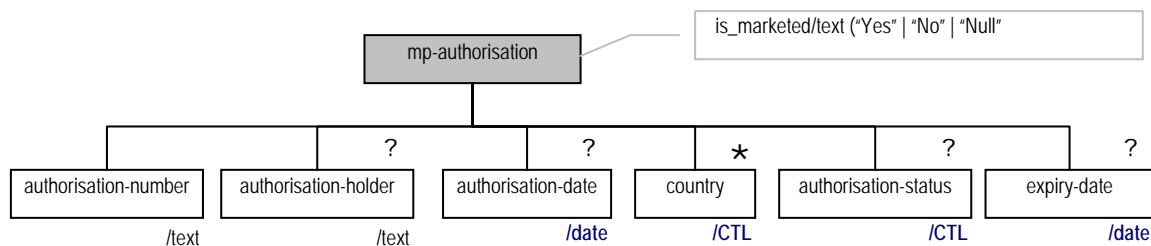

### Actor

#### Actor (Business Concept)

Element	definition	RDM 3.0 Mapping	Remarks for Structure/type/rule/format or other
Actor	Actor is any individual or organisation that is involved in or affected by any activities relating to human and veterinary medicinal products.	Not mapped	

	Examples of Actor are: marketing authorisation holder, manufacturer, sponsor... [Regulation (EC) N° 726/2004 (see article 2)]		
<Role-name>	The role played by a given party (organisation/person) in one or more activities (manufacturing, marketing authorisation, clinical trials etc.) related to a medicinal product. This entity combines the parties with their roles for a particular activity. Example(s): Ranbaxy Laboratories Ltd with role Manufacturer of active substance to medicinal product Sertraline Omega 50 mg coated tablet Any individual or organisation that is involved in or affected by any activities relating to human and veterinary medicinal products.	Role > comments	Values="Applicant" "member-state-of-source" "person-responsible" "on-behalf-of-applicant" "contact-blood-vaccine"...
Role	The element containing the <role-name> information	Role > Party	

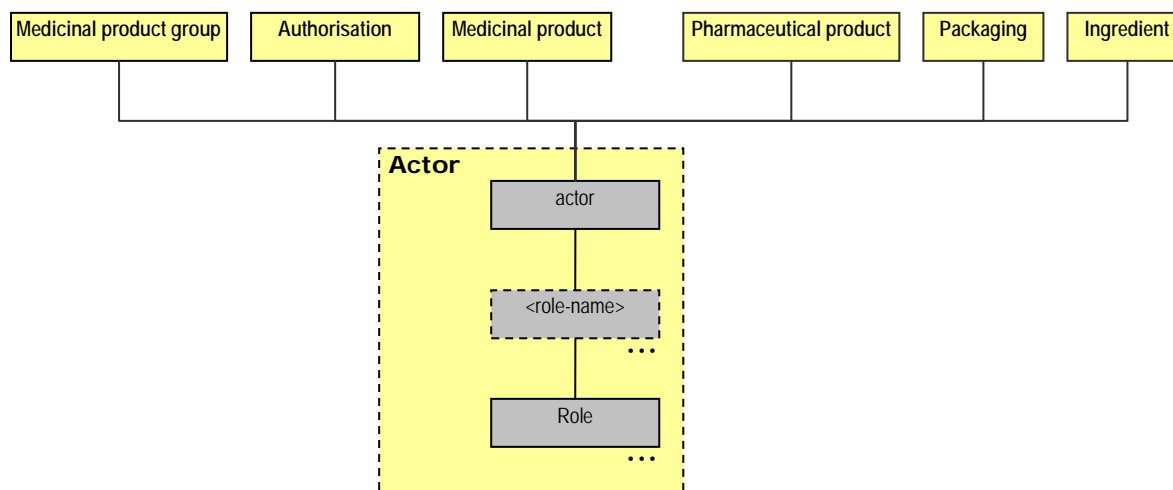

### Actor (Technical Concept)

DES 3.0 Element	Definition	RDM 3.0 Mapping	Remarks for Structure/type/rule/format or other
role	See business concept	Role > Party >	
party-identification		party-identification	
party-identification-type	Indicate by which kind of information the party can be uniquely identified. Examples: Tax Number, Social Security Number, VAT Number, Duns Number (Number assigned to the site as per Data Universal Numbering System), GS1 Number, WHO Number, ISO/HI-7 Identifier ????	party-identification-type	
identification-number	The number that uniquely identifies the party	identification-number	
party-relationship-type	See Party relationship type CTL	-relationship-type	
business-category	See Business category CTL	business-category	
party-type	See Party type CTLs	party-type	
job-title	Research Analyst, Pharmacist	person > job-title	
given-name	Given name of the person.	person > given-name	
middle-name	Middle name of the person.	middle-name	
family-name	Family name of the person.	person > family-name	
initials	Person's initials.	person > initials	
qualification	See qualification CTL	person > qualification	
gender	See Gender CTL	person > gender	
name	Name of the party	Organisation > name	
contact-details	See contact detail technical concept	Contact details	

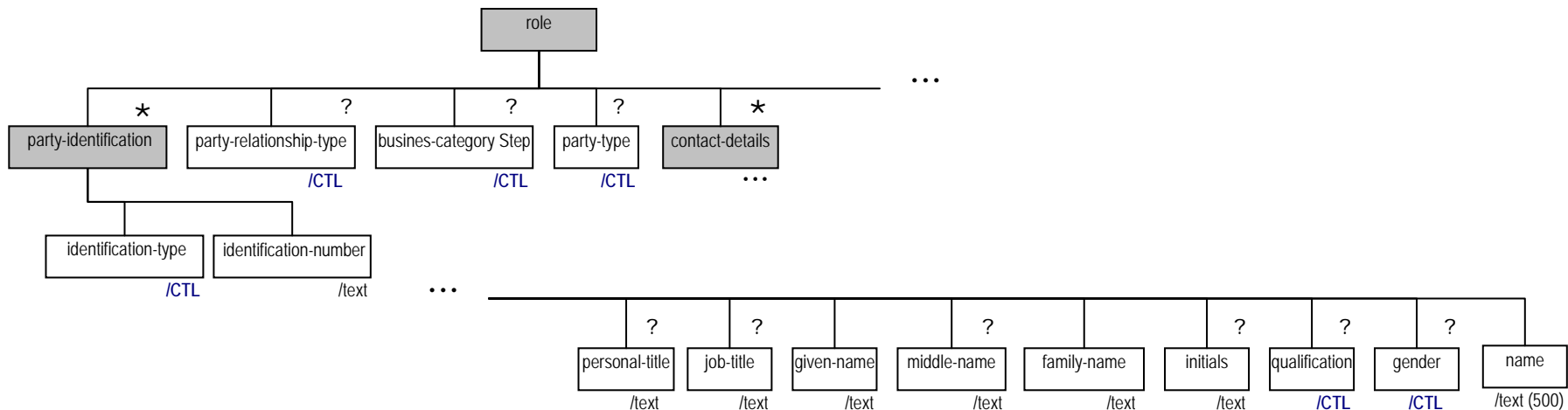

**Contact details (Technical Concept)**

Used in: Role

DES 3.0 Element	Definition	RDM 3.0 Mapping	Remarks for Structure/type/rule/format or other
contact-details	This entity contains the identifiers for contact details for the parties. One party will have only one contact detail identifier. This entity serves the purpose of an umbrella for all contact information like Address, Phone, Fax and Email.	Contact Details >	
address	Address of the contact.	Address > address line 1 Address > address line 2 Address > address line 3 Address > address line 4 Address > address line 5	
city	Town or city of the contact.	Address > city	
state	State or province	Address > state	

DES 3.0 Element	Definition	RDM 3.0 Mapping	Remarks for Structure/type/rule/format or other
country	Country	Address > Country CTL	
post-code	Post code of the party. E.g. post code for 'Pfizer Limited' is 'CT13 9NJ'	Address > post-code	
phone	Phone number	electronic-contact > electronic-contact-type = "Phone" electronic-contact > electronic-contact	
fax	Fax number	electronic-contact > electronic-contact-type = "Fax" electronic-contact > electronic-contact	
email	Electronic mail address	electronic-contact > electronic-contact-type = "e-mail" electronic-contact > electronic-contact	
qualification	Qualification of the person	Party > Person > Qualification	

### Element Tree Diagram

#### 8.1.12.

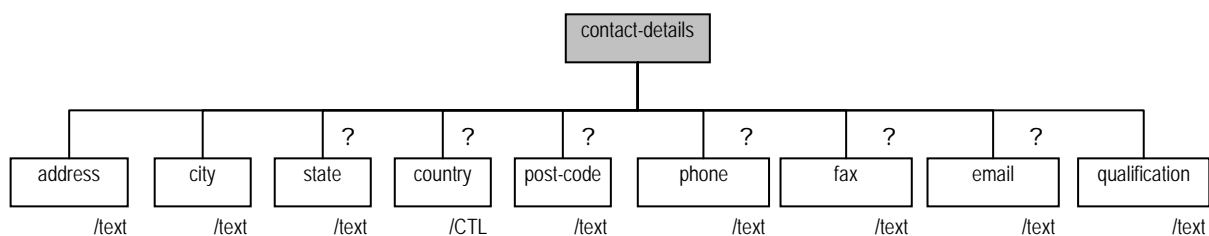

## Target population

### *Target population (Business Concept)*

DES 3.0 Element	Definition	RDM 3.0 Mapping	Remarks for Structure/type/rule/format or other
Medicinal product	The group of patients/animals described by domain, gender, age range, race and/or species who might be treated by the medicinal product.	Medicinal Product	
Target population	See target population business concept	Target Population	

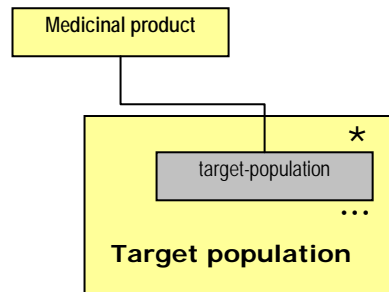

**Target-population (Technical Concept)**

DES 3.0 Element	Definition	RDM 3.0 Mapping	Remarks for Structure/type/rule/format or other
target-population		Target Population >	
domain	The list of areas where a medicinal product or a term can be used (Human use, Veterinary use, Human and Veterinary use...)	Medicinal Product > Medicinal Product Group > domain	
gender	See used CTLs	Gender CTL	
age-range	See used CTLs	Age Range CTL	
species	See used CTLs	Species CTL	
race	See used CTLs	Race	

**Element Tree Diagram**

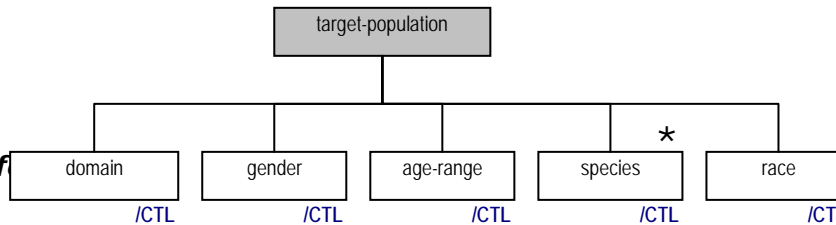

**8.2. Common application f**

**8.2.1. Application**

**Application (Business concept)**

DES 3.0 Element	Definition	RDM 3.0 Mapping	Remarks for Structure/type/rule/format or other
Application	The application is the process steps that	Application	



DES 3.0 Element	Definition	RDM 3.0 Mapping	Remarks for Structure/type/rule/format or other
	defines the all the information requested by the regulator to get an authorisation.		
Declaration	The declaration identifies who applies for the application and what are their responsibilities.	Not mapped	
Application-reference	See Application concept	Application	
legislation	See Legislation concept	Not mapped	
reference-medicinal-product	See reference Medicinal Product concept	Reference Medicinal Product	
scientific-advice	See Scientific advice concept	App Scientific Advice	
Authorisation	See authorisation concept	MP Authorisation	
Attachment	See Attachment concept	ignored	

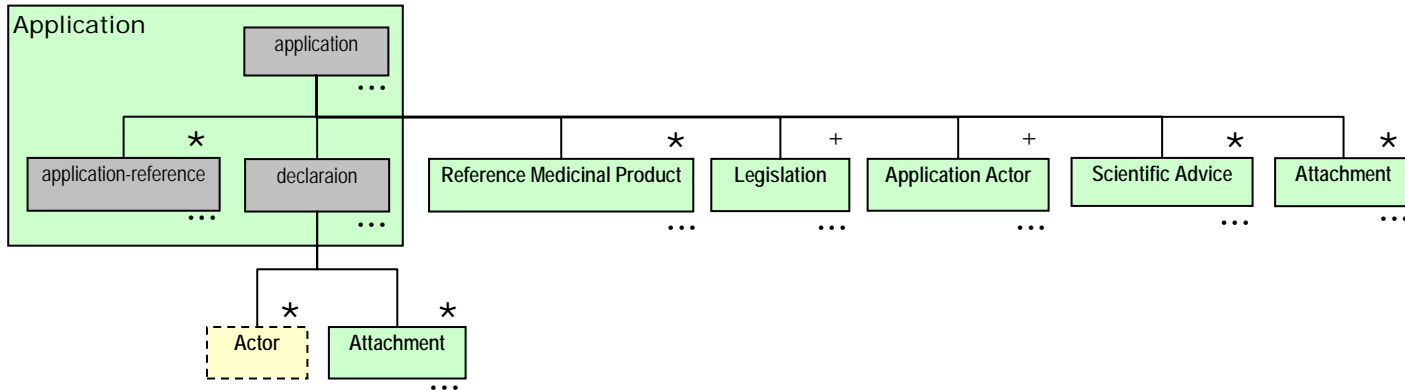

**Application (Technical concept)**

DES 3.0 Element	Definition	RDM 3.0 Mapping	Remarks for Structure/type/rule/format or other
Application	An application is done for only one medicinal product except for a centralised procedure where multiple medicinal product are tolerated	Application >	This is valid in the context of the initial-application form human and vet.
:type	See application-type CTL The type of application submitted by the applicant. It stands for the form title.	Application Type CTL > term id	Origin: All forms
has_CHMP-scientific-advice	Determine if a Scientific advice was given by CHMP	App Scientific Advice > was scientific advice given App Scientific Advice > Scientific Advice Source CTL	
has_NCA-scientific-advice	Determine if a Scientific advice was given by NCA	App Scientific Advice > was scientific advice given App Scientific Advice > Scientific Advice	

DES 3.0 Element	Definition	RDM 3.0 Mapping	Remarks for Structure/type/rule/format or other
		Source CTL	
acceptance-date	The date of acceptance of the application by the CHMP or CVMP	MP Procedure >chmp acceptance date	
application-reference	The other marketing authorization applications for the same medicinal product inside or outside the EEA.	-	
type	The type of reference authorisation	Not mapped	
country	Country filter inside or outside EEA	MP Authorisation > Country CTL > term id	
authorisation-number	The number of the authorisation	MP Authorisation > authorisation number	
application-status	See authorisation-status CTL	MP Authorisation >Authorisation Status CTL > Term id	To be checked.
application-status-date	Authorisation date	MP Authorisation > authorisation date	
invented-name	The most common invented name	Medicinal Product >Medicinal Product Group > invented name	
application-status-reason	Reason for the reference application status	MP Authorisation > authorisation description	
application-differences	Differences with the current application	Other MA Application > differences description Other MA Application > are there differences	
declaration	See section 0	-	

**Element Tree Diagram**

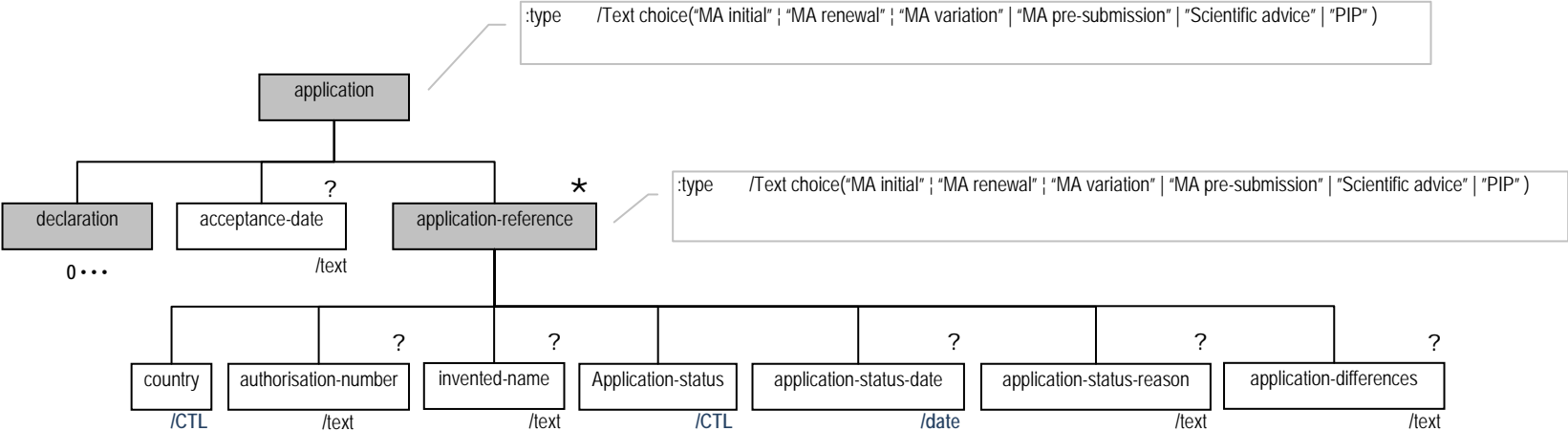

**Declaration (technical concept)**

DES 3.0 Element	Definition	RDM 3.0 Mapping	Remarks for Structure/type/rule/format or other
declaration	The declaration provides the identification and authentication information of the application	Application >	
authorised-person			
dec-signature	The digital signature of the applicant if any	Not mapped	
dec-place-signature	The geographical place where the signature took place	place signature	
dec-date-signature	The date when the application was signed	signature date	
actor	The role assigned to the authorised-person element	Role > Party	Values: "applicant"; "main-signatory"; "second-signatory"
payment	The payment associated to the application which is subject to various ratifications depending on the sme-status.	ignored	Origin: Variation, Renewal
payment-amount	The amount to be paid for the application processing	ignored	
payment-currency	The currency in which the payment is done	ignored	
payment-status	See payment status CTL The status of the payment transaction (not-paid, in-process, paid, refused)	ignored	CTL to be defined (optional -> mandatory if payment-amount is <> 0)
condition	See declaration condition CTL The list of condition fulfilled or not in a foliation declaration	App Information Proposal CTL > term id	Origin: Variation

**Element tree diagram**

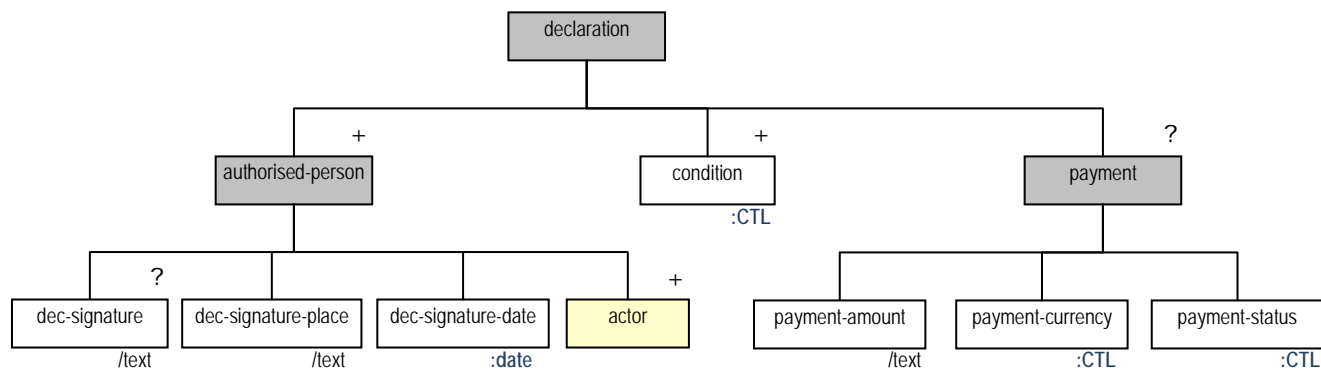

**8.2.2. Attachment**

**Attachment (business concept)**

Element	Definition	DRM 3.0 Mapping	Remarks for Structure/type/rule/format or other
Attachment	The declaration identifies who applies for the application and what are their responsibilities.	ignored	
<business concept>	Any business concept		

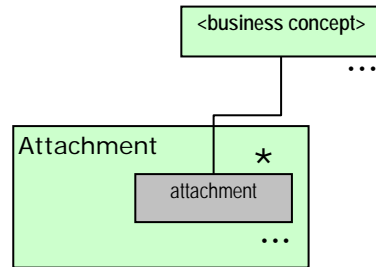

**Attachment (technical concept)**

DES 3.0 Element	Definition	RDM 3.0 Mapping	Remarks for Structure/type/rule/format or other
Attachment	Any document that need to be added with the application form	ignored	The name of the control term value
Attachment-type	The term id that identifies the attachment or document ex: "letter of consent", "GMP certificate", "letter of authorization", "CV of qualified person", etc. see attachment-type CTL		
Attachment-URL	The URL/URI to the document		
Attachment-body	Base 64 encoded attachment body		Note: Foreseen in case of base 64 encoding

**Element Tree Diagram**

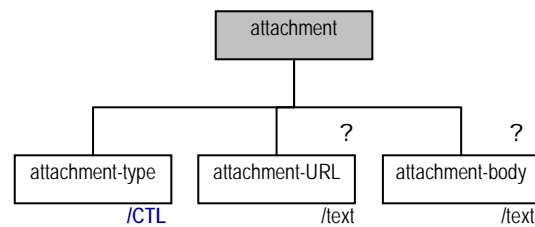

### 8.2.3. Reference Medicinal Product

#### Reference Medicinal Product (Business Concept)

DES Element	Definition	RDM 3.0 Mapping	Remarks for Structure/type/rule/format or other
Reference Medicinal Product	Represent at the medicinal product that already complies with the E.U or National legislation and is used as a reference in the context of the application.		The link to the medicinal product is kept through an internal reference id.
medicinal-product-group	Copy of medicinal-product-group technical concept	See Medicinal product business concept	
medicinal-product	Copy of medicinal-product technical concept	See Medicinal product business concept	
pharmaceutical-product	Reference of pharmaceutical-product technical concept	See Pharmaceutical product business concept	
mp-authorisation	Reference of mp-authorisation technical concept	See Authorisation business concept	

The Reference medicinal product may be used by (under) any common application form concept if the reference medicinal product clearly linked to that concept. The medicinal product RDM concept is reused under the Reference medicinal product to avoid the proliferation of internal references.

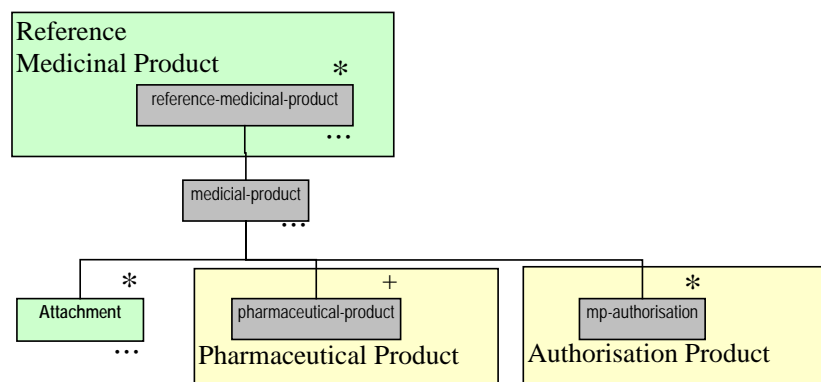



**Reference Medicinal Product (technical concept)**

DES 3.0 Element	Definition	RDM 3.0 Mapping	Remarks for Structure/type/rule/format or other
reference-medicinal-product (rmp)	Represent an identified part of the EU or National legislation to which the medicinal product or the application complies with.		
medicinal-product-group	-	-	Elements kept: is-gmo
medicinal-product	-	-	<ul style="list-style-type: none"> <li>Elements kept: domain mp-renewal-date</li> <li>Elements added: medicinal-product-type (inherited from medicinal-product-group) invented-name (inherited from medicinal-product-group)</li> </ul>
pharmaceutical-product	-	-	
mp-authorisation	-	-	
difference	Represent the differences between the reference medicinal product and the medicinal product for which the application is made. See difference CTL	Specified in Annexes where the element is used	
dif-reason	The reason to the difference to exists	-	
dif-difference-item	Difference or changes between the reference medicinal product and the application product (change of bioavailability, change of pharmacokinetics, change or addition of a new strength / potency, change or addition of a new pharmaceutical form, change or addition of a new route of administration, change(s) in the raw	-	

DES 3.0 Element	Definition	RDM 3.0 Mapping	Remarks for Structure/type/rule/format or other
	material(s), change(s) in the manufacturing process(es), change in therapeutic indication(s), change in pharmaceutical form(s), change in strength (quantitative change to the active substance(s)), change in route of administration(s), other)		
dif-difference-other	When the difference does not exist in any controlled term list	-	

**Element Tree Diagram**

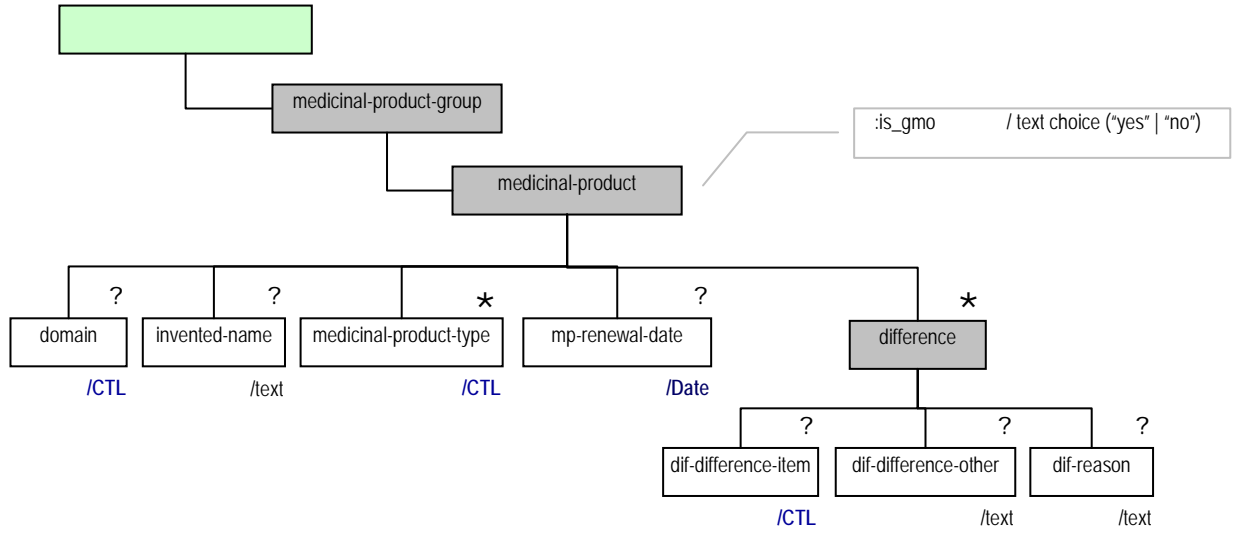

**8.2.4. Legislation**

**Legislation (business concept)**

DES 3.0 Element	Definition	RDM 3.0 Mapping	Remarks for Structure/type/rule/format or other
legislation	Represents an identified part of the E.U or National legislation to which the medicinal product or the application complies or does not comply with.		

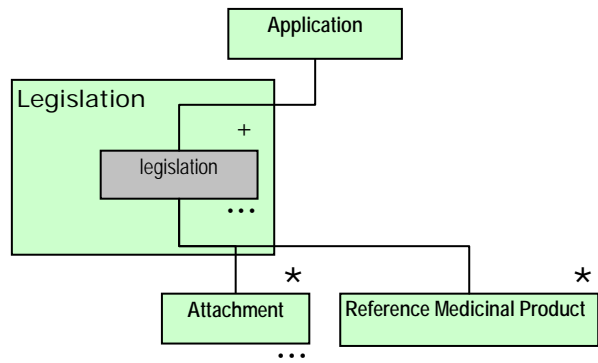

**Legislation (technical concept)**

DES 3.0 Element	Definition	RDM 3.0 Mapping	Remarks for Structure/type/rule/format or other
Legislation (leg)		Specified in annexes	
:leg_type	Defines the type of legislation: directive   "regulation"   "national"	-	"directive"   "regulation"
:leg_applies	Determine is the applicants comply or not with the specific legislation.		"yes"   "no"
leg-eu-code	The European code for the law See legislation-code CTL	-	Format : directive: YYYY/9999/EC or Regulation: 9999/YYYY The format depends on the leg-type
leg-national-code	The national code of the law See legislation-code CTL	-	
leg-country	The country for which the legislation applies see the Country CTL	-	(no filter)
leg-usage	The usage context of the legislation element if the code is not sufficient to determine the context of application. Ex ("new active substance"; "known active substance" are referred together in one paragraph of the legislation...) See legislation usage CTL	-	
country	The country where the legislation usage applies	-	
legislation-usage	List of usage values identifying a sub part of a legislation article	-	
legal-status-for-supply	List of the supply types used in the MAA form	-	
leg-comment	Note or comment associated to the legislation in the context of the application	-	

DES 3.0 Element	Definition	RDM 3.0 Mapping	Remarks for Structure/type/rule/format or other
leg-article		-	
:leg_applies	Determine is the applicants comply or not with the specific legislation.	-	"yes"   "no"
leg-article-number	The article that is part of the legislation if any		Format: article 999.[99] [annex 99]
leg--usage	The usage context of the legislation article element if the code is not sufficient to determine the context of application. Ex ("renewable delivery", "not renewable delivery" ...)	-	

### Element Tree Diagram

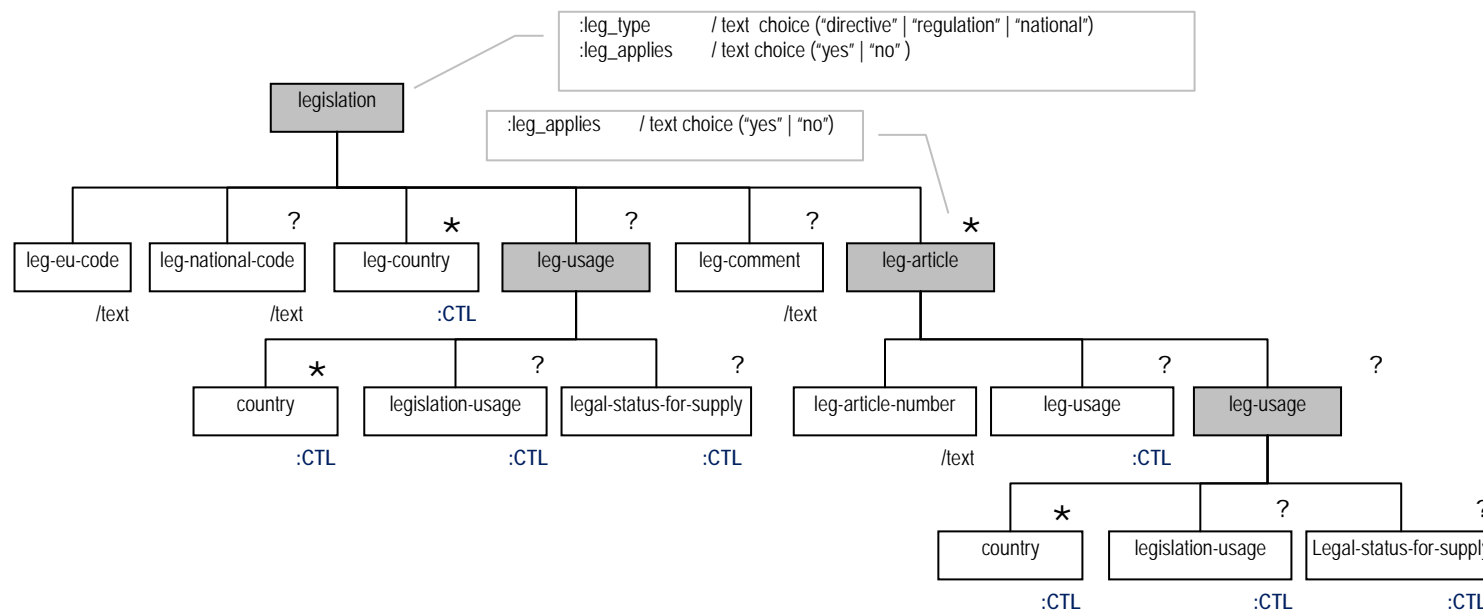

## 8.2.5. Application Actor

### *Application Actor (Business concept)*

DES 3.0 Element	Definition	RDM 3.0 Mapping	Remarks for Structure/type/rule/format or other
Reference actor	Any actor related to the current application. .	Specified in annexes	This is used to - assign the same actor to different roles - refer to an actor already defined elsewhere in the model. - define an actor not foreseen in the RDM model or for which interoperability info is not relevant.
sme-status	The small to Medium enterprise status provided by the emea	Specified in annexes	Defined by the <a href="#">Recommendation 96/280/EC</a> Legislation("Regulation 726/2004")/ article( "70.2")/leg_applies="yes"
Gmpc	God Manufacturing Process certificate: This entity contains the header level information for a GMP Certificate issued by a National Competent Authority to some company site	Specified in annexes	
Mia	This entity contains the header level information for a MIA (Manufacturing and Importation Authorisation) issued by a National Competent Authority to some company site(s)	Specified in annexes	

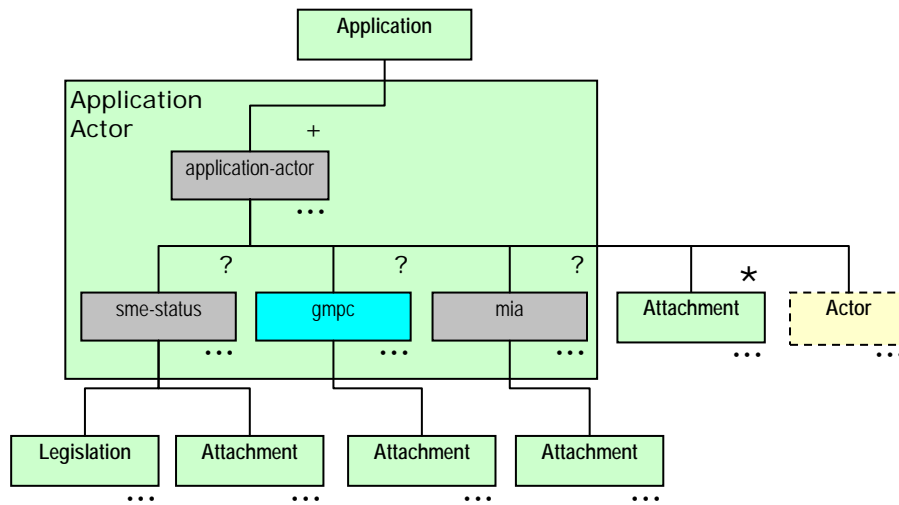

**Application Actor (Technical concept)**

DES 3.0 Element	Definition	RDM 3.0 Mapping	Remarks for Structure/type/rule/format or other
reference-actor		Specified in annexes	
actor-activities	Activities (test, process functions,...) performed by the actor depending on its role (mainly the Manufacturer)	-	
name-qualified-person	According to 2001/83/EC The qualified person is responsible in particular for carrying out the duties specified in Article 51 and fulfils the conditions of qualification set out in paragraphs 2 and 3 of article 49.	-	
actor-reference			Not used



DES 3.0 Element	Definition	RDM 3.0 Mapping	Remarks for Structure/type/rule/format or other
gmpc	This entity contains the header level information for a GMP Certificate issued by a National Competent Authority to some company site	-	
gmpc-category	The category is fixed to the value "GMP Certificate" See gmpc-category	-	Default value
gmpc-number	GMPC reference number	-	
inspection-date	Last GMP inspection date	-	
authorisation-number	EudraGMP Manufacturing Authorisation reference	-	
gmp-detail	This entity holds detail level information (authorised dosage forms, activities etc) for a GMP Certificate	-	
gmp-activity	category of products and activities inspected see GMP activity CTL	-	
mia	This entity contains the header level information for a MIA (Manufacturing and Importation Authorisation) issued by a National Competent Authority to some company site(s).	-	
mia-number	The authorization number delivered by the National Competent Authority	-	
sme-status	The status given by the EMA in order to receive fee reductions on a application.	-	
ema-sme-number	The reference by which the SME status is registered by the EMEA	-	
date-of-expiry	The expiration date of the sme status	-	

**Element tree diagram**

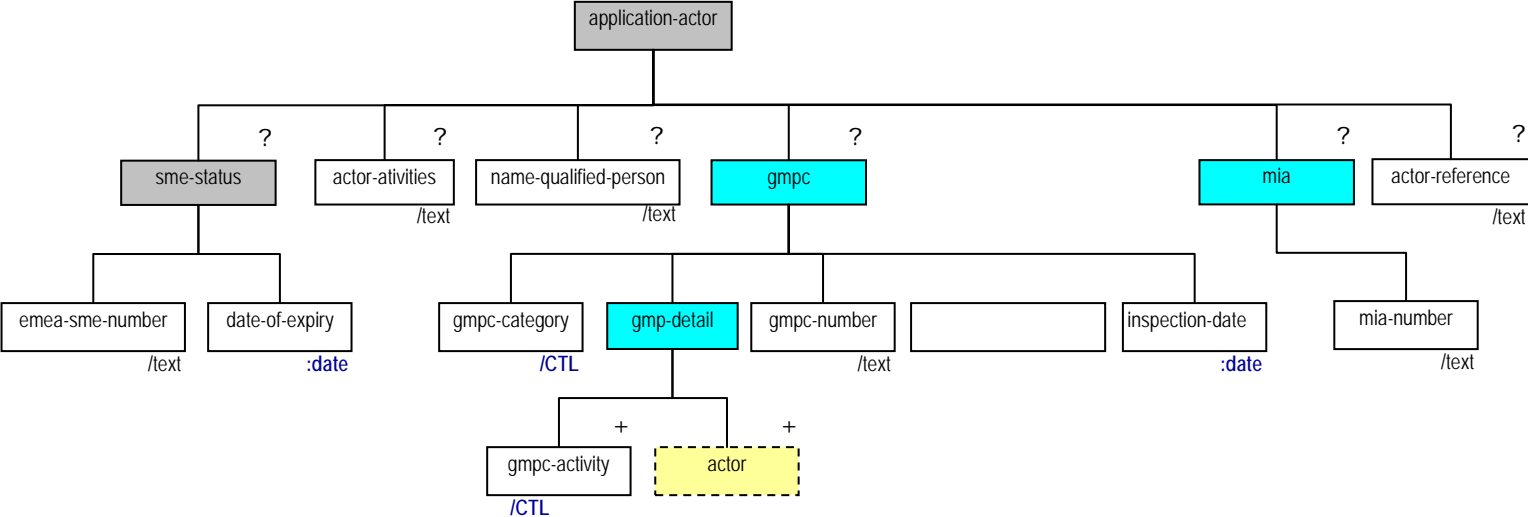

## 8.2.6. Orphan designation

### *Orphan designation (business concept)*

DES 3.0 Element	Definition	RDM 3.0 Mapping	Remarks for Structure/type/rule/format or other
Orphan designation	<p>The designation criteria are laid down in Article 3(1) of Regulation (EC) No 141/2000</p> <p>A medicinal product shall be designated as an orphan medicinal product if its sponsor can be established:</p> <ul style="list-style-type: none"> <li>not more than five in 10 thousand persons in the Community when the application is made or would not generate sufficient return to justify the necessary investment;</li> <li>that there exists no satisfactory method of diagnosis, prevention or treatment of the condition in question that has been authorised in the Community or, if such method exists, that the medicinal product will be of significant benefit to those affected by that condition</li> </ul>	-	Designation as an orphan medicinal product is governed by Articles 3 and 5 of Regulation (EC) No 141/2000
Legislation	Legislation="Regulation (EC) 141/2000":/article="3(1)(b)" and "that there exists no satisfactory method of diagnosis, prevention or treatment of the condition in question that has been authorised in the Community or, if such method exists, that the medicinal product will be of significant benefit to those affected by that condition"	See technical concept	Determine if the orphan designation is a significant benefit.
Legislation	Legislation="Regulation (EC) 141/2000"/article="8.1": "...the Community and the Member States shall not, for a period of 10 years, accept another application for a marketing authorisation, or grant a marketing authorisation or accept an application to extend an existing marketing authorisation, for the same therapeutic indication, in respect of a similar medicinal product"	See technical concept	Determine the market exclusivity terms according to the different regulations.

DES 3.0 Element	Definition	RDM 3.0 Mapping	Remarks for Structure/type/rule/format or other
Legislation	Legislation="Regulation (EC) 141/2000"/article="5.1": In order to obtain the designation of a medicinal product as an orphan medicinal product, the sponsor shall submit an application to the Agency at any stage of the development of the medicinal product before the application for marketing authorisation is made.	See technical concept	Used to determine if an OD was submitted.
Legislation	Legislation="Regulation (EC) 141/2000"/article="5.9" "The designated medicinal product shall be entered in the Community Register of Orphan Medicinal Products."	See technical concept	

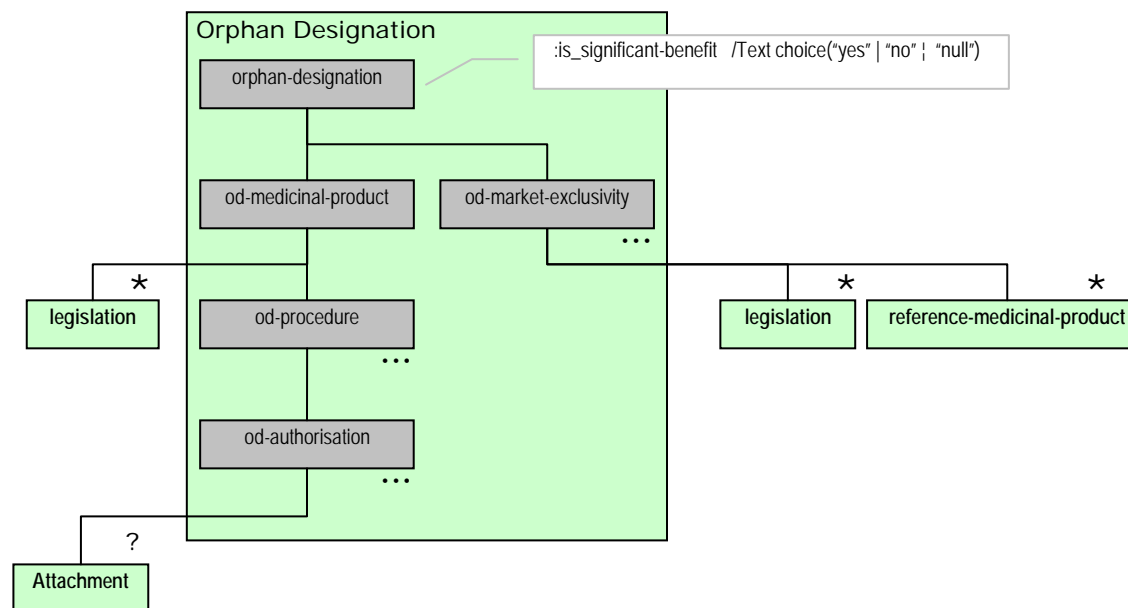

**Orphan designation (technical concept)**

DES 3.0 Element	Definition	RDM 3.0 Mapping	Remarks for Structure/type/rule/format or other
orphan designation	The designation criteria are laid down in Article 3(1) of Regulation (EC) No 141/2000	Orphan Designation >	Designation as an orphan medicinal product is governed by Articles 3 and 5 of Regulation (EC) No 141/2000
Is_significant-benefit	“that there exists no satisfactory method of diagnosis, prevention or treatment of the condition in question that has been authorised in the Community or, if such method exists, that the medicinal product will be of significant benefit to those affected by that condition”	is based significant benefit	Note: from “Regulation (EC) 141/2000”) article 3(1)(b)” Determine if the orphan designation is a significant benefit.
od-medicial-product	-	-	
or-procedure	The procedure number associated to the application for or eu orphan designation.	Not mapped	
odp-number	EMA procedure number	od procedure number	Format=“ EMA/OD/XXX/yyyy”
odp-start-date	Date on which the procedure was started.	Not mapped	
od-authorisation	The orphan designation authorisation associated to the medicinal product	-	
oda-eu-register-number	the Number in the Community Register of Orphan Medicinal Products	od community reg number	Format=“EU/X/XX/XXX”
oda-date	The date of one of the final status (“granted”, “refused”, “withdrawn”)	od status date	
oda-status	The current status of the authorisation. See the authorisation status CTL	Authorisation Status CTL > term id	
oda-decision-reference-number	The reference number from the copy of the Commission Decision on orphan designation	od decision ref number	
attachment	copy of the Orphan Designation Decision	ignored	Value = “copy of the Orphan Designation Decision”

DES 3.0 Element	Definition	RDM 3.0 Mapping	Remarks for Structure/type/rule/format or other
od-marketing-exclusivity	-	-	
oda-eu-register-number	EU Orphan Designation Number(s)	OD Number > eu od number	

**Element tree diagram**

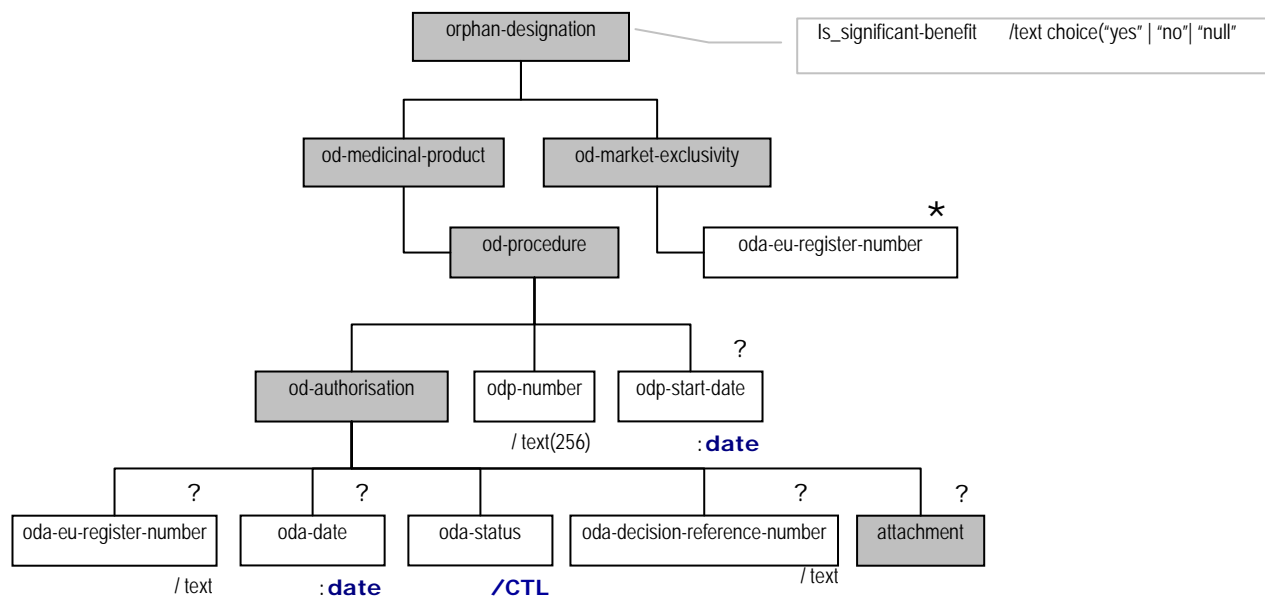

Business Rules				
Rule ID	DES 3.0 Element	Default BR	Rule	Effect(s)/ Remarks
1	oda-decision-reference-number	optional	TRUE(oda-status == "refused")	Mandatory

Business Rules				
2	attachment	optional	TRUE(oda-status == "granted")	Mandatory
3	oda-date	optional	TRUE(oda-status != "pending")	Mandatory
5	oda-eu-register-number	optional	TRUE(oda-status == "granted")	Mandatory
	/orphan-designation /Legislation	mandatory	VALUE(Legislation="Regulation (EC) 141/2000"/article="8":leg_applies ) = VALUE(application/orphan-designation:has_market-exclusivity)	

## 8.2.7. Paediatric Designation

### *Paediatric designation (business concept)*

DES 3.0 Element	Definition	RDM 3.0 Mapping	Remarks for Structure/type/rule/format or other
Paediatric designation	REQUIREMENTS ACCORDING TO REGULATION (EC) N° 1901/2006 ('PAEDIATRIC REGULATION'):	Paediatric Designation	
paediatric-investigation-plan	Procedure by which the PDCO gives his decision on paediatric use for specific medicinal product indications	-	
waiver	Procedure by which the PDCO gives his decision on a prohibited paediatric use specific medicinal product indications	-	

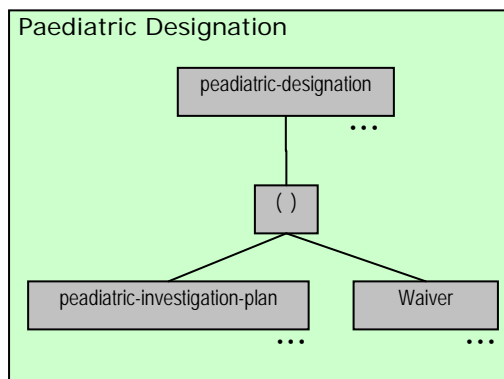

**Paediatric designation (technical concept)**

Element	Definition	RDM 3.0 Mapping	Remarks for Structure/type/rule/format or other
paediatric-investigation-plan	-	Paediatric Designation >	
pip-decision-number	PDCO decision number of the pip decision document	art 30 pip decision number art 8 pip decision number	
waiver	-	-	



Element	Definition	RDM 3.0 Mapping	Remarks for Structure/type/rule/format or other
waiver-type	The type of waiver used for one or more indications See Waiver-type CTL	Not mapped	
waiver-decision-number	The decision number	art 7 class waiver number art 7 product waiver number art 8 product waiver number art 8 class waiver number	
pip-compliance	-	-	
parallel-procedure-number	The procedure numbers of any parallel, ongoing or previous variation(s) or extension(s) containing paediatric data relevant for the full PIP compliance verification	parallel applications desc	
document-reference	Reference used to identify the document describing the PIP-compliance submitted to the competent organisation	nca emea doc reference	
reference-type	The type of party used as a reference for the PIP compliance see reference-type CTL	Not mapped	

**Element tree diagram**

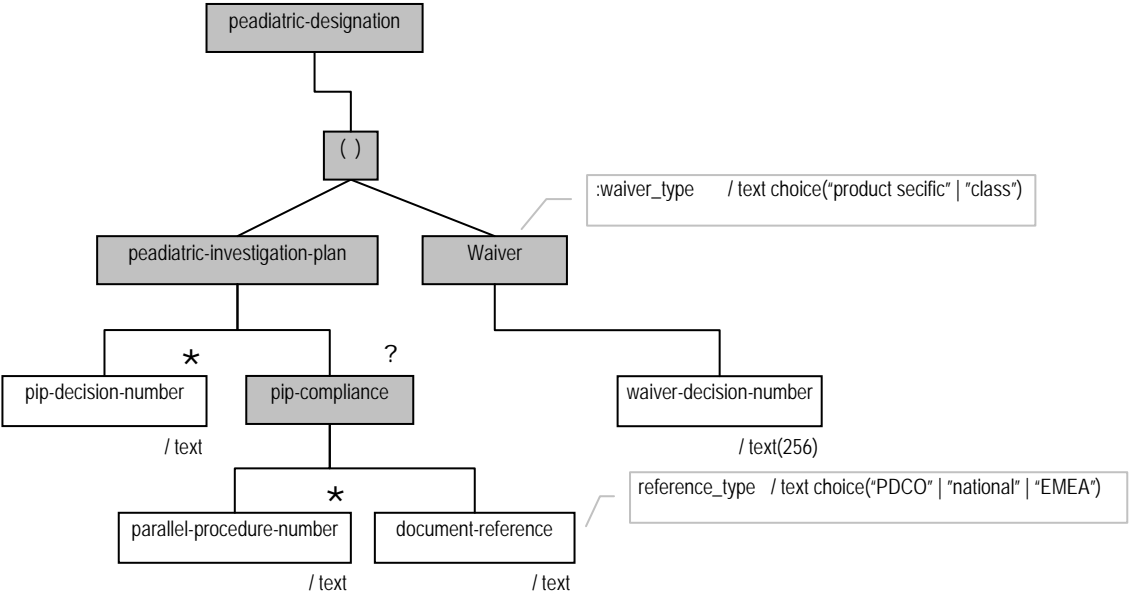

## 8.2.8. Substance Certificates

### *Substance Certificate (Business Concept)*

DES 3.0 Element	Definition	RDM 3.0 Mapping	Remarks for Structure/type/rule/format or other
Substance Certificate	<p>The substance certificates supports the following certificates for the interoperable information of MAA to be transmitted between parties</p> <p>An Active Substance Master File (ASMF): also known as the European Drug Master File (EDMF) is the active substance section of dossiers for a marketing authorisation application.</p> <p>Vaccines Antigen Master File (VAMF): One given VAMF contains all relevant information of biological, pharmaceutical and chemical nature for one given vaccine antigen, which is common to several vaccines from the same MA applicant or MAH</p> <p>The European Pharmacopoeia (the CEP) can be used by the manufacturer of medicinal product in its application for marketing authorisation to demonstrate the compliance of the substance used with the monographs of the European Pharmacopoeia as referred in Directive 2001/83/EC</p> <p>The Plasma Master File (PMF) is a compilation of all the required scientific data on the quality and safety of human plasma relevant to the medicines, medical devices and investigational products that use human plasma in their manufacture. These data cover all aspects of the use of plasma, from collection to plasma pool.</p>	<p>App PMF Certificate            Vaccine Antigen Master File            European Drug Master File</p>	

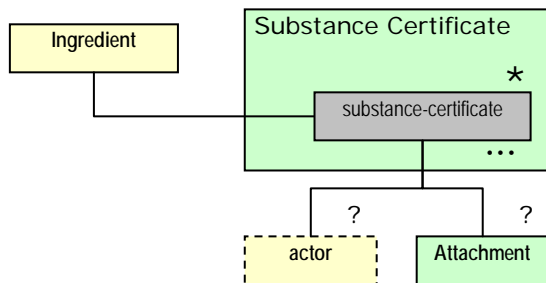

**Substance Certificate (technical concept)**

DES 3.0 Element	Definition	RDM 3.0 Mapping	Remarks for Structure/type/rule/format or other
substance-certificate	A certificate/master file required for quality assessment.	Vaccine Antigen Master File > European Drug Master File > App PMF Certificate >	
country	See country CTL The country in which the certificate is issued	Not mapped	Found in an example for initial application human
substance-name	Name of the substance referenced by the certificate See substance CTL	Vaccine Antigen Master File > Substance CTL > term id European Drug Master File > Substance CTL > term id not mapped for App PMF Certificate	Note 1

DES 3.0 Element	Definition	RDM 3.0 Mapping	Remarks for Structure/type/rule/format or other
reference-number-certificate	The unique reference number of the certificate used in the application	Vaccine Antigen Master File > reference number European Drug Master File > reference number App PMF Certificate > certificate ref number	
date-submission	The date the certificate was submitted	Vaccine Antigen Master File > submission date European Drug Master File > submission date App PMF Certificate > submission date	
date-last-update	The last update of the certificate	Vaccine Antigen Master File > last update date European Drug Master File > last update date App PMF Certificate > approval or last update date	

**Element tree diagram**

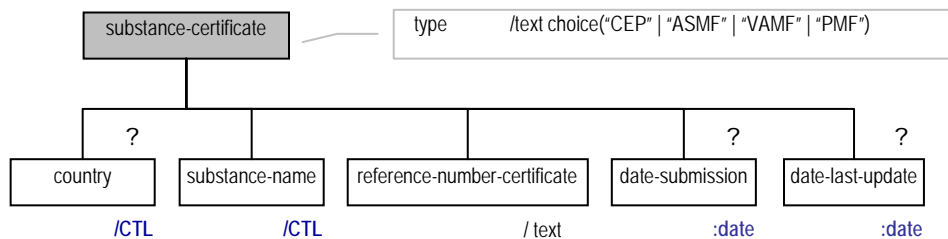

**8.3. Scientific advice**

**Scientific advice (business concept)**

DES 3.0 Element	RDM Specific Format	Definition	RDM 3.0 Mapping	Remarks for Structure/type/rule/format or other
scientific-advice	-	Advice will be given on the design and conduct of trials necessary to demonstrate the quality, safety and efficacy of the medicine in the target population	App Scientific Advice	
advice		Element containing information about the scientific advice	App Scientific Advice	

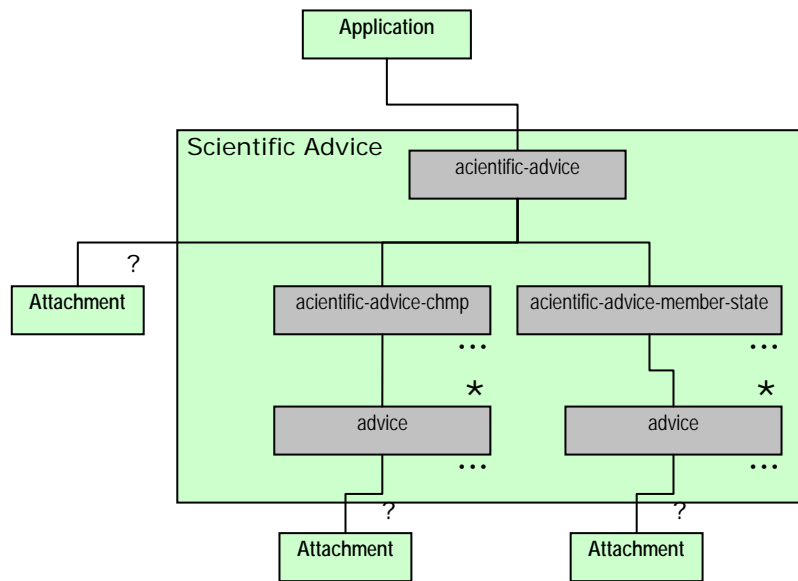

**Scientific advice CHMP / member state (technical concept)**

DES 3.0 Element	RDM Specific Format	Definition	RDM 3.0 Mapping	Remarks for Structure/type/rule/format or other
scientific-advice-chmp scientific-advice-member-state	-	Scientific Advice	App Scientific Advice	-
advice-type	IDENTIFIER+ TERMNAME	The type of scientific advice that can be asked by the applicant. (EMEA scientific advice, EMEA protocol assistance, National Competent Authorities advice, FDA written request, other opinion/decision/advice)  See scientific-advice-type	Not mapped	
advice	-	-	-	
scientific-advice-source	IDENTIFIER+ TERMNAME	The list of the sources for scientific advice related to clinical trial.: CHMP (Committee for Medicinal Products for Human use), NCA (National Competent Authority))  See scientific-advice-source CTL	Scientific Advice Source CTL	
scientific-advice-reference	TEXT	The registered number of the scientific advice	scientific advice ref	
scientific-advice-date	DATE	The date the scientific advice was issued by the medical agency (EMEA or National).	scientific advice date	
scientific-advice-status	IDENTIFIER + TERMNAME	The status of the current advice (received, planned, pending)  see scientific-advice-status CTL	app pending in other ms	
national-agency	-	-	-	
	IDENTIFIER	The country of the national agency, source of the	Country CTL > term id	



DES 3.0 Element	RDM Specific Format	Definition	RDM 3.0 Mapping	Remarks for Structure/type/rule/format or other
country	+ TERMNAME	scientific advice		

**Element Tree Diagram**

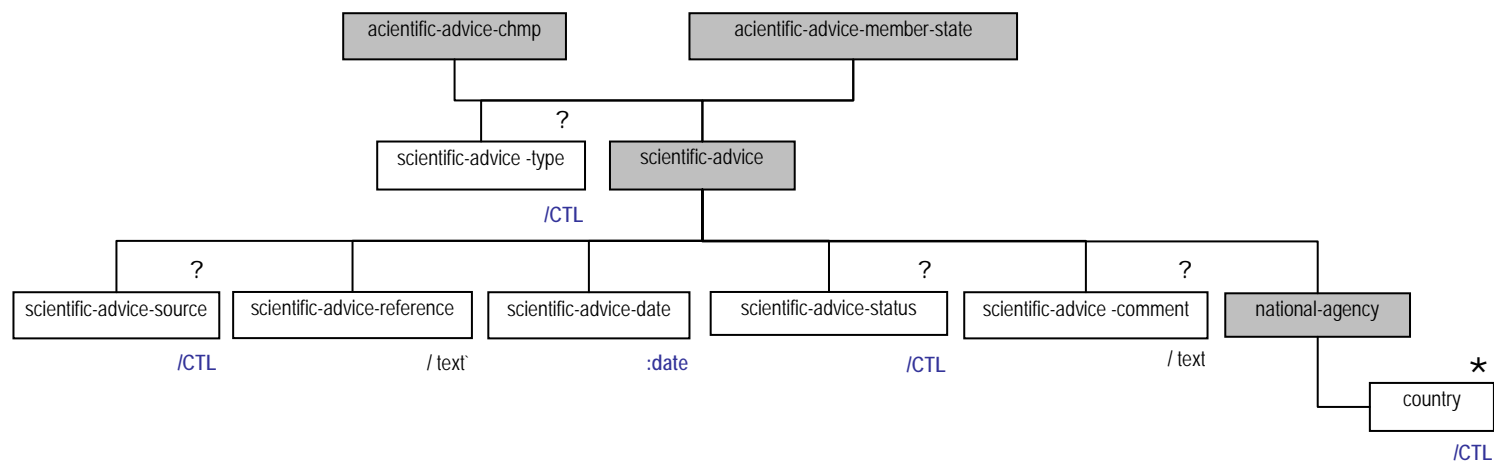

Business Rules				
Rule ID	DES 2.0 Element	Default BR	Rule	Effect(s)/ Remarks
1	scientific-advice	optional	application/: has_CHMP-scientific-advice="yes"	mandatory
1.1	scientific-advice-source	mandatory	Value="CHMP"	
2	scientific-advice	optional	application/: has_NCA-scientific-advice="yes"	Mandatory
2.1	scientific-advice-	mandatory	Value="NCA"	

Business Rules				
	source			
2.2	scientific- advice/national- agency	optional	-	Mandatory.

### 8.3.1. Specific Application Form

This section makes the link between the common application concepts and the specific application form concepts.

Element	Label	Remarks for Structure/type/rule/format or other
application-form (af)	-	
Initial-af-human	Module 1: Administrative information Application form	
initial-af- veterinary	VOLUME 6B Presentation and content of the dossier-Part 1 Summary of the dossier Part 1A Application form	
variation-af	APPLICATION FOR VARIATION TO A MARKETING AUTHORISATION	
renewal-af	APPLICATION FOR RENEWAL OF A MARKETING AUTHORISATION	
<form>-af	Is the template for form to be supported in the future	

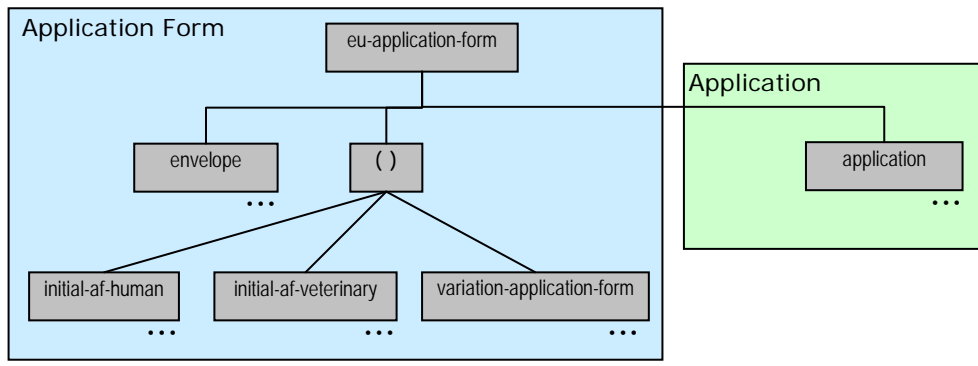

## 9. About this Document

### 9.1. Definitions, Acronyms, and Abbreviations

#### 9.2. Acronyms

Name	Definition
cms	concerned member state
DCP	Decentralised Procedure
DTD	Data Type Definition
ETD	Element Tree Diagram
EU	European Community
MA	Marketing Authorisation
MAH	Marketing Authorisation Holder
MS	Member State
MRP	Mutual Recognition Procedure
NP	National Procedure
TSE	Transmissible Spongiform Encephalopathy
XML	eXtended Markup Language
XSL	XML Stylesheet Language

#### 9.2.1. Abbreviations

Name	Definition
Nmbr, num.	Number